



## DESIGN & FABRICATION OF GEAR CUTTING ATTACHMENT FOR LATHE MACHINE

<sup>1</sup>Sutar Rajendra Sidharam, <sup>2</sup>Kalashetti Shankar Basawaraj, <sup>3</sup>Lohar Deepak Shrikant, <sup>4</sup>Phopale Y.A  
S.V.S.M.D's K.K.I. Polytechnic, Akkalkot, <sup>1,2,3</sup> Lecturer Department of Mechanical Engineering  
S.V.S.M.D's K.K.I. Polytechnic, Akkalkot

### ABSTRACT

The paper aims at designing and fabrication of gear cutting attachment to lathe. In the present work, I made an attempt to design and fabricate an attachment for a gear cutting for a medium duty lathe. This attempt will reduce the investment for medium and small scale industries, sub sequent reduce the manufacturing cost of gears. The attachment to lathe can perform an indexing mechanism like milling machine and carriage function, to and fro movement and sliding on a bed. The attachment was mounted on carriage, where we fixed the work piece and a mandrel was designed to hold the cutting tool. This mandrel was attached to the head stock spindle which is the main source for rotation of the cutting tool. The attachment was carefully designed after studying the proper mechanisms, power requirements and force analysis on work material and a cutting tool.

*Key Words: Design, Fabrication, Indexing Mechanism, Mandrel, Gear Cutting.*

### INTRODUCTION

**Lathe:** The lathe is one of the oldest machine tools and is to remove metal from a piece of work to give it the required shape and size.

**Centre lathe:** The lathe machine used for the project is Centre lathe, a lathe consists of a bed, a head stock, a carriage with a cross slide, and a tool post mounted on the cross slide. The spindle which carries the work holding device is driven by a motor usually through a gear box for obtaining various speeds. The carriage moves on the bed guide ways, parallel to the axis of the work spindle, and the cross slide provides the transverse motion. The required power for the movements is obtained through a feed shaft geared to the spindle drive.

Lathes are designed in a variety of versions to suit different applications. They are also produced in different precision classes and in different sizes. The cutting speed, feed, and depth of cut is adjusted accordingly on the lathe machine. The various cutting speeds can be adjusted by changing the lever on the lathe. The recommended feed rates are given on the machine. Depth of cut can be adjusted on the tool post. Instructions are followed from the lathe manual.

**Gear:** A gear is a rotating machine part having cut teeth, which mesh with another toothed part in order to transmit torque. Gear cutting is the process of creating a gear. The most common processes include hobbing, broaching, and machining; other processes include shaping, forging, extruding, casting, and powder metallurgy. Gears are commonly made from metal, plastic, and wood.

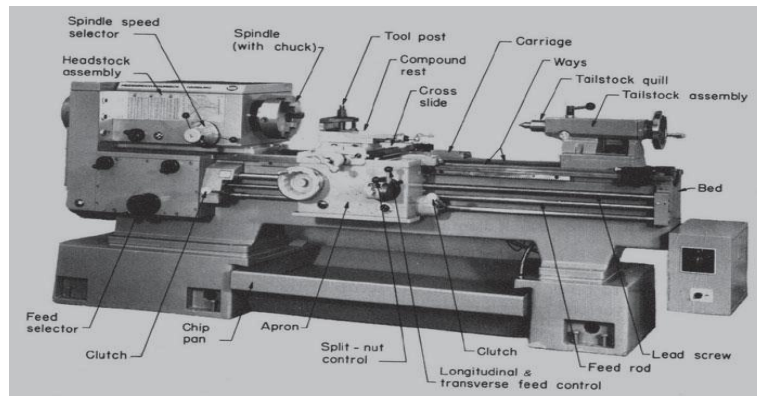
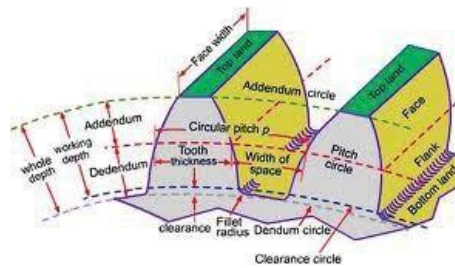

Fig (1): Centre lathe

**TYPES OF GEARS:**

1. External vs. Internal Gears: An external gear is one with the teeth formed on the outer surface of a cylinder or cone. An internal gear is one with the teeth formed on the inner surface of a cylinder or cone.
2. Spur Gear: Spur gear consists of cylinder or disk with the teeth projecting radially, and although they are not straight-sided in form, the edge of each tooth is straight and aligned parallel to axis of rotation.
3. Helical Gear: The Helical gear edges of the teeth are not parallel to the axis of rotation, but are set at an angle. Since the gear is curved, this angling causes the tooth shape to be a segment of a helix.
4. Double Helical Gears: A double helical gear can be thought of as two mirrored helical gears joined together. However, double helical gears are more difficult to manufacture due to their more complicated shape.
5. Bevel Gears: A bevel gear is shaped like a right circular cone with most of its tip cut off.
6. Spiral Bevels Gears: Spiral bevel gears have curved teeth at an angle allowing tooth contact to be gradual and smooth.
7. Hypoid Gears: Hypoid gears resemble spiral bevel gears except the shaft axes do not intersect. The pitch surfaces appear conical but, to compensate for the offset shaft, are in fact hyperboloids of revolution. Hypoid gears are almost always designed to operate with shafts at 90 degrees.
8. Worm Gears: Worm gears can be considered a species of helical gear, but its helix angle is usually somewhat large (close to 90 degrees) and its body is usually fairly long in the axial direction.
9. Rack and Pinion Gears: A rack is a toothed bar or rod that can be thought of as a sector gear with an infinitely large radius of curvature. Torque can be converted to linear force by meshing a rack with a pinion: the pinion turns; the rack moves in a straight line.
10. Epicyclic Gear: In epicyclic gearing one or more of the gear axes moves.
11. Sun and Planet Gears: Sun and planet gearing was a method of converting reciprocating motion into rotary motion in steam engines.
12. Harmonic Drive Gears: A harmonic drive is a specialized gearing mechanism often used in industrial motion control, robotics and aerospace for its advantages over traditional gearing systems, including lack of backlash, compactness and high gear ratios.
13. Differential Gears: Differential gears are referred to an arrangement of gears, connecting two axles in the same line and dividing the driving force between them. One axle is allowed to turn faster than the other.

Spur Gear Definition: Gears whose axes are parallel and whose teeth are parallel to the Centre line of the gear are called spur gears.



### Spur Gear Nomenclature

Fig (2): Spur Gear Nomenclature

1. Pitch Circle: It is an imaginary circle which by pure rolling action, would give the same motion as the actual gear.
2. Pitch Circle Diameter: It is the diameter of the pitch circle. The size of the gear is usually specified by the pitch circle diameter. It is also called as pitch diameter.
3. Pitch Point: It is a common point of contact between two pitch circles.
4. Pitch Surface: It is the surface of the rolling discs which the meshing gears have replaced at the pitch circle.
5. Pressure angle or angle of obliquity: it is the angle between the common normal to two gear teeth at the point of contact and the common tangent at the pitch point. It is usually denoted by  $\phi$ . The standard pressure angles are 141/20 and 200.
6. Addendum: It is the radial distance of a tooth from the pitch circle to the top of the tooth.
7. Dedendum: It is the radial distance of a tooth from the pitch circle to the bottom of the tooth.
8. Addendum circle: It is the circle drawn through the top of the teeth and is concentric with the pitch circle.
9. Dedendum circle: It is the circle drawn through the bottom of the teeth. It is also called root circle.
10. Circular Pitch: It is the distance measured on the circumference of the pitch circle from a point of one tooth to the corresponding point on the next tooth. It is usually denoted by  $p_c$ .

Mathematically, Circular pitch,  $p_c = M D/T$

Where D = Diameter of the pitch circle, and T = Number of teeth on the wheel

11. Diametral pitch: It is the ratio of number of teeth to the pitch circle diameter in millimetres. It denoted by  $p_d$ . Mathematically, Diametral pitch,  $p_d = T/D$

Where T = Number of teeth, and D = Pitch circle diameter.

12. Module: It is the ratio of the pitch circle diameter in millimetres to the number of teeth. It is usually denoted by  $m$ .

Mathematically, Module,  $m = D/T$  Where D=Pitch circle diameter, T=Number of teeth

13. Clearance: It is the radial distance from the top of the tooth to the bottom of the tooth, in a meshing gear. A circle passing through the top of the meshing gear is known as clearance circle.

14. Total depth: It is the radial distance between the addendum and the dedendum circle of a gear. It is equal to the sum of the addendum and dedendum.

15. Working depth: It is radial distance from the addendum circle to the clearance circle. It is equal to the sum of the addendum of the two meshing gears.

16. Tooth thickness: It is the width of the tooth measured along the pitch circle.
17. Tooth space: It is the width of space between the two adjacent teeth measured along the pitch circle.
18. Backlash: It is the difference between the tooth space and the tooth thickness, as measured on the pitch circle.
19. Face width: It is the width of the gear tooth measured parallel to its axis
20. Profile: It is the curve formed by the face and flank of the tooth.
21. Top land: It is the surface of the top of the tooth.

In unigraphics the individual components are designed and assembled for the gear cutting turning attachment to lathe. They are:

1. Base Plate
2. Gear Housing
3. Worm wheel
4. Worm shaft
5. Shaft
6. Cutter
7. Mandrel
8. Index Plate
9. Ball bearing
10. Bush bearing
11. Cover Plate
12. Index Heading
13. Final assembly of attachment for Gear Cutting

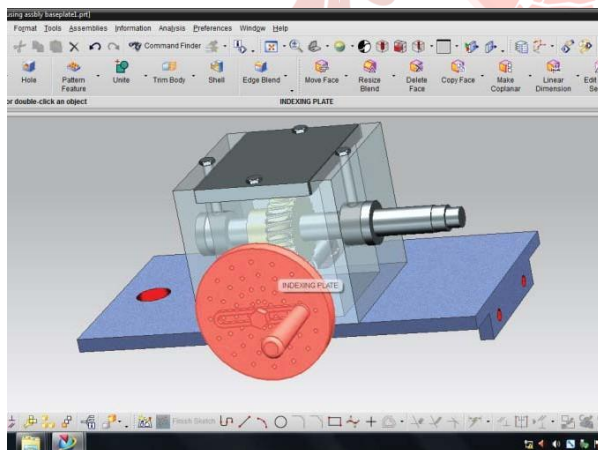

Fig (3): Final Assembly of Attachment for Gear Cutting  
*FABRICATION ATTACHMENT TO LATHE:*

*Base Plate:* A base plate serves as a base or support. Number of holes is provided on it so that it can be fixed to the lathe by making use of bolts. A base plate should have enough strength and stiffness to bear the weight of the whole equipment. Other properties of the base plate include sharp finish, high rigidity, quick functionality, and compact size. The material used for the fabrication of this part is mild steel with the dimensions of 305mm×165mm×10mm. The operations involved in this manufacturing process are: cutting, milling and surface grinding.



Fig (4):Base Plate

*Gear Housing:* The main Purpose of gear housing is, it supports the both worm wheel and worm shaft. The material is used for this manufacturing process is mild steel. The operations involved in this manufacturing process are cutting, milling, surface grinding, welding and Jig boring

*Worm wheel and Worm shaft*

Fig (5): Gear Housing



Fig 6(a): Worm wheel

The main purpose of worm wheel and worm shaft is, it gives the rotation to work piece after completion of the single gear cutting operation. The material selected for the worm wheel is cast iron and for worm shaft is EN8. For holding the worm wheel, a shaft is manufactured by the material EN8 was selected and the manufacturing process are involved for fabrication of the shaft are turning, drilling. The operations involved for the manufacturing of worm shaft are turning, threading.

*Index Plate and Crank:*

The main purpose of this Index plate it gives distance between teeth to teeth of gear by the rotation of index pin on index plate. The material selected for Index plate and crank is mild steel. The operations involved in manufacturing process are cutting, milling, drilling, and surface grinding.



Fig (7): Index Plate and Crank

**Mandrel:** The purpose of a mandrel is a device for holding and rotating a hollow piece. The material selected for this manufacturing process is EN8 material. The processes involved in this manufacturing process are turning, facing, drilling.



Fig (8): Mandrel

**Bolts and Nuts:** A nut is a type of hardware fastener with a threaded hole. Nuts are almost always used opposite a mating bolt to fasten a stack of parts together. The two partners are kept together by a combination of their threads friction, a slight stretch of the bolt, and compression of the parts. In applications where vibration or rotation may work a nut loose, various locking mechanisms may be employed: Adhesives, safety pins or lock wire, nylon inserts, or slightly oval-shaped threads. A screw, or bolt, is types of fastener characterized by a helical ridge, known as an external thread. The most common uses of screws are to hold objects together and to position objects.



Fig (9): Bolts and Nuts

**Cutter:** The main purpose of cutter is to cutting the gear or gear blank. The material of cutter is High Speed Steel. The diameter of cutter is 48mm and number of teeth on cutter is 14. The properties of HSS are high hardness, high abrasion resistance and high temperature resistance.



Fig (10): Cutter

### Gear Cutting Attachment to Lathe

Fig (11): Gear Cutting Attachment to Lathe

*Mechanism of Gear Cutting Attachment to Lathe:* First remove the compound slide from lathe and the attachment is fixed on the cross slide with bolts and nuts. The cutter is tightened to the mandrel with the nut. Now the mandrel is placed in the head stock of the lathe. The work piece is placed on the work piece and tightened that. The operation is started by switch on lathe. The mandrel is rounded around itself and its cuts the work piece. This operation is continued till the output gets.



The output of the Gear Cutting Attachment to Lathe

Fig (12): The output of the Gear Cutting Attachment to Lathe



*Cost effectiveness in spur gear manufacturing:* Compare with other methods this is the cheap and best method to small and medium scale Industries INSPECTION

### Gear Profile Measurements

An inspection is an organized examination or formal evaluation exercise. In engineering activities inspection involves the measurements, tests, and gauges applied to certain characteristics in regard to an object or activity. The results are usually compared to specified requirements and standards for determining whether the item or activity is in line with these targets. The aim of this inspection is to find following parameters of gears Pitch circle diameter, Major diameter, Root diameter, Addendum, Dedendum, Circular pitch, Tooth thickness. The equipment is used for this inspection is Tool maker microscope.



*Tool Maker Microscope:*

A general view of the small model of tool maker’s microscope giving it is design and it is optical system is shown in figure. This is designed for measurement of parts of complex figure profiles of external threads, tool templates and gauges. It can be used to measure centre to centre difference of holes in dry plane as well as in co-ordinate measuring systems. Basically it consists of the optical hand which can be adjusted vertically along the guide ways of the supporting column. The optical head can be in any portion by screw. The working table on which parts to be inspected are placed on a heavy hollow box. The table has a compound slide by means of which the measurement part has longitudinal and lateral movement. The beam of the light passes through transparent glass plate on which parts to be checked are placed.



			
Standard gear		Manufactured gear	
Pressure Angle	20°	Pressure Angle	20°
Teeth Number	17	Teeth Number	17
Pitch diameter(mm)	25	Pitch diameter(mm)	25
Module(mm)	1.471	Module(mm)	1.47
Diametral Pitch(mm)	0.68	Diametral Pitch(mm)	0.68
Circular Pitch(mm)	4.62	Circular Pitch(mm)	4.62
Addendum(mm)	1.471	Addendum(mm)	1.47
Dedendum(mm)	1.701	Dedendum(mm)	1.53
Tooth thickness(mm)	2.31	Tooth thickness(mm)	2.39
Clearance(mm)	0.231	Clearance(mm)	0.240
Outside diameter(mm)	28	Outside diameter(mm)	28
Bore diameter(mm)	15	Bore diameter(mm)	15
Total depth(mm)	3.403	Total depth(mm)	3.24
Working depth(mm)	2.941	Working depth(mm)	2.76
Base diameter(mm)	23.492	Base diameter(mm)	23.11
Root diameter(mm)	21.597	Root diameter(mm)	21.23

Table: Comparison between standard and manufactured gear values

## CONCLUSIONS

1. The medium

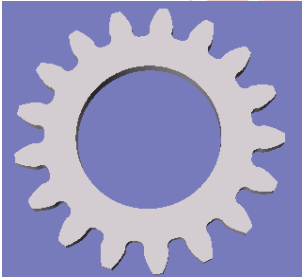
2. Duty centre lathe of standard power 2.5kw is capable of cutting spur gears.
3. Gears up to a diameter of 30mm and module between 1 to 2 can be generated
4. The profile comparison proved the quality obtained is comparable to milling.
5. The attachment can be up graded for machining mild steel gears.
6. The manufacturing cost of gear may be reduced by this method which will be helpful to small and medium industry.

## REFERENCES

- [1] T. Moriwaki [2008], "Multi-functional machine tool", CIRP Annals - Manufacturing Technology, Page No: 736-749.
- [2] Evgeny Podzharov, Vladimir Syromyatnikov, Julia Patricia Ponce Navarro and Ricardo Ponce Navarro [2008], "Static and Dynamic Transmissin Error in Spur Gears", the Open Industrial and Manufacturing Engineering Journal, Volume No: 1, Page No: 37-41.
- [3] Sachidananda HK, Joseph Gonsalvis and Prakash HR [2012], "Analysis of contact stresses in altered tooth-sum spur gearing", Journal of Applied Mechanic Engg 1:103, Volume No:1, Issue No:0, Page No:1-5.
- [4] T.T.Petry-Johnson, A.Kahraman, N.E.Anderson, D.R.Chase[2007], "Experimental Investigation Of Spur Gear Efficiency", Proceedings of the ASME 2007 International Design Engineering Technical Conferences & Computers and Information in Engineering Conference, IDETC/CIE 2007, September 4-7, Las vegas, Nevada, USA, DETC2007-35045.
- [5] G. Madhusudan, C.R. Vijayasimha [1987], "Approach to Spur Gear Design", Computer-Aided Design, Volume 19, Issue 10, December, Pages No: 555-559.
- [6] Ajoy Kumar Das[1997], "Technological heredity in spur gear manufacturing", Journals of Materials Processing Technology, Bangladesh Institute of Technology Dhaka, Page No:66-74.
- [7] Patel K.P.[2012], "Experimental analysis on surface roughness of CNC end milling process using Taguchi design method", International Journal of Engineering Science and Technology, Volume 4 No. 02, ISSN: 0975-5462, Page No: 540-545.