

---

**Industry Automation Using Programmable Switching in Repetitive Nature Of Work**

Mrs. Surabhi Tankkar<sup>1</sup>  
Armiet Engineering College  
Surabhi.Tankkar@gmail.com

---

---

**ABSTRACT**

Our aim of this project is designed to control substation load shedding and sharing using a programmable switching control by automatically. In this project we demonstrate the working of this simple operation using a Microcontroller. The development of this application requires the configuration of the program through GSM module. In substation, there are many tasks like certain loads need to be switched on/off in specific time intervals. In this, the loads can be operated in three modes: Set mode, Auto mode and Manual mode. In set mode, through timers, the operation is based on input time set by the user where as in auto mode it works on default time settings and finally in the manual mode it functions while respective loads are operated depending on the load necessity using GSM. All the modes and status of loads are displayed on an LCD. Finally GSM modem which sends sms to the control system we can select the mode and timing remotely.

**Keywords** – Automation, Control System, Microcontroller, Embedded System, 8051, AT89S52, SIM300.

---

---

**1. INTRODUCTION**

Controlling of electric power substation equipments plays an important role in daily maintenance of electric power system. In an extra high voltage substation, the reliability required from substation components is critical. Applications of controlling base station with the help of mobile of substation equipments could improve the quality of accelerating the process of any substation. Our aim is to control the Substation equipments through a mobile phone.

Here we are using a GSM Based Modem technology connected end-to-end, with one end to the distribution side and other to the mobile device. The mobile device used here makes the control of equipments of the substation on a global basis. Here

we are going to control the distribution side equipments Switch Gears and Relays.

**2. METHODOLOGY USED**

Our projects functionality of system involves in to following steps: In this block diagram the gsm which sending sms to the controller through max232 then the controller performs the operation by read the message (i.e.)controller gives signal to the relay driver that controls the feeder.

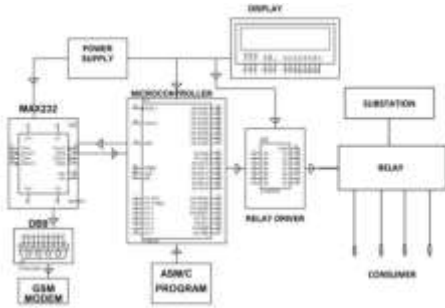

### 3. COMPONENTS

#### A. AT89S52 Microcontroller

The AT89S52 is a low-power, high-performance, inexpensive CMOS 8-bit microcontroller with 8K bytes of Insystemprogrammable flash memory. The device is manufactured using Atmel's high-density nonvolatile memorytechnology and is compatible with the industry-standard 80C51 instruction set and pin-out. The on-chip flash allowsthe program memory to be reprogrammed in-system or by a conventional nonvolatile memory programmer. Bycombining a versatile 8-bit CPU with in-system programmable flash on a monolithic chip, the Atmel AT89S52 is apowerful microcontroller which provides a highly-flexible and cost-effective solution to many embedded controlapplications.

#### B. Level Shifter IC MAX232

The MAX232 is an integrated circuit that converts signals from an RS-232 serial port to signals suitable for use inTTL compatible digital logic circuits. The MAX232 is a dual driver/receiver and typically converts the RX, TX, CTSand RTS signals. The drivers provide RS-232 voltage level outputs (approx.  $\pm 7.5$  V) from a single + 5 V supply viaon-chip charge pumps and external capacitors. The receivers reduce RS-232 inputs (which may be as high as  $\pm 25$  V),to standard 5 V TTL levels. These receivers have a typical threshold of 1.3 V, and a typical hysteresis of 0.5 V.MAX232 IC will convert a TTL Logic 0 to between +3 and +15V, and it will convert a TTL Logic 1 to between -3 to-15V, and vice versa for converting from RS232 to TTL.

#### C. Relay Driver ULN2003

Relay Driver ULN2003 is a high voltage, high current Darlington transistor array containing seven open collectorDarlington pairs with common emitters. It consists of seven NPN Darlington pairs that feature high voltage outputswith common cathode Clamp diodes for switching inductive loads. The collector current rating of a single Darlingtonpair is 500 mA. For higher current capabilities, the pairs can be paralleled. ULN2003 is used to interface relays withthe microcontroller since the maximum output of the microcontroller is 5V with too little current delivery and is notpracticable to operate a relay with that voltage.

#### D. Electromagnetic Relay



Relay is an electromagnetic device which is used to isolate two circuits electrically and connect them magnetically. For example, a relay can make a 5V DC battery circuit to switch a 230V AC mains circuit. Thus a small sensor circuit can drive, say, a fan or an electric bulb. A relay switch can be divided into two parts: input and output. Operating voltages like 6V, 9V, 12V, 24V etc.Input part - 2 Coil Pins : These pin are the control switch which is connected to electromagnet through which we can control the operation of relay. Here low voltage is applied to create magnetism. Output part - Normally Open Contact (NO) – NO contact is also called a make contact. It closes the circuit when the relay is activated. It disconnects the circuit when the relay is inactive. Normally Closed Contact (NC) – NC contact is also known as break contact. This is opposite to the NO contact. When the relay is activated, the circuit disconnects. When the relay is deactivated, the circuit connects.

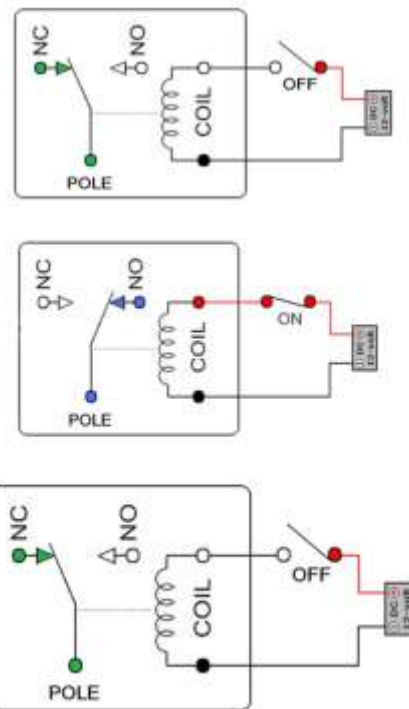

#### E. LCD

Liquid Crystal Display (LCD) consists of rod-shaped tiny molecules sandwiched between a flat

piece of glass and an opaque substrate. These rod-shaped molecules in between the plates align into two different physical positions based on the electric charge applied to them.

When electric charge is applied they align to block the light entering through them, whereas when no-charge is applied they become transparent. Light passing through makes the desired images appear. This is the basic concept behind LCD displays. LCDs are most commonly used because of their advantages over other display technologies. They are thin and flat and consume very small amount of power compared to LED displays and cathode ray tubes (CRTs).

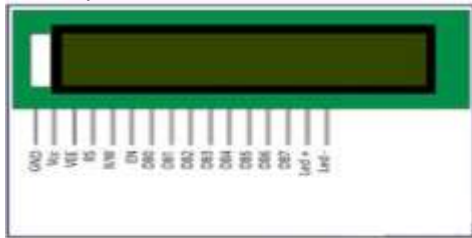

A 16x2 LCD means it can display 16 characters per line and there are 2 such lines. This LCD has two registers, namely, Command and Data. The command register stores the command instructions given to the LCD. A command is an instruction given to LCD to do a predefined task like initializing it, clearing its screen, setting the cursor position, controlling display etc. The data register stores the data to be displayed on the LCD. The data is the ASCII value of the character to be displayed on the LCD.

Just like most of the currently available electrical devices and home appliances, the project is powered by an onboard power supply containing transformer for AC source, a bridge rectifier to convert to DC source and a voltage regulator to get 5V DC source. The power supply will provide 5V to the Atmel AT89S52 microcontroller, level shifter IC MAX232, ULN2003 Relay Driver and a 16x2 LCD module.

**4. IMPLEMENTATION AND RESULT**

The system was simulated according to the block diagram given in Figure 1. For the sake of

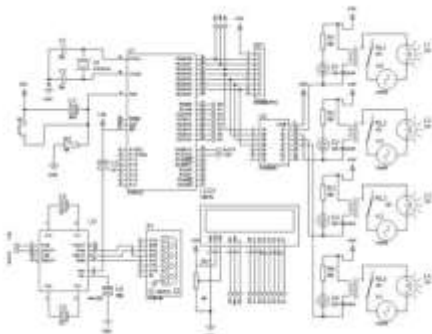

simplicity and flexibility, instead of sending full commands like “Turn ON LOAD 1”, the user can send a single number to command. A simple formula was developed that can be used to know which number to send to turn ON/OFF any load. Load numbers can be set by the user. A single controller can control up to 28 loads. The system was simulated using Proteus v7.7 and the results found to be in the expected lines. The C program used in the system was written using Keil compiler and was added to the simulated module. International Journal of Latest Trends in Engineering and Technology (IJLTET) sss **Power Supply**

**5. CONCLUSION**

Our paper presents an inexpensive GSM-based interactive control system. A number of literatures related to the topic of control systems and automation were reviewed and analyzed. According to the proposed system, the host can be any cell phone and the client is a controller based on Atmel AT89S52. The controller is connected to a GSM modem through an RS232 cable and a level shifter IC. The paper provided explanation of the circuit diagram of the proposed system. The project circuit diagram was designed using Proteus v7.7 designing software. Also, a prototype of the system was assembled with the required components on a PCB (Printed Circuit Board). The system proved to be efficient and practical. The proposed system is economical and efficient in comparison with the similar systems developed so far.

**REFERENCES**

- [1]. A. Jadhav, and P. Gadhari, “Interactive Voice Response (IVR) and GSM Based Control System”. *Proceedings of the National Conference "NCNTE-2012". Mumbai, 2012*
- [2]. I. Petrov, S. Seru, and S. Petrov, “HOME AUTOMATION SYSTEM”, *School of Engineering Science, 2011.*
- [3]. D. Rudrapalet. al. “Automated Load Shedding Period Control Systems”, *International Journal on Computer Sc. & Engineering, Vol 3, Issue 5, pp. 1159 - 1168, May 2011.*
- [4]. E. Yavuz, et al., “Safe and Secure PIC Based Remote Control Application for Intelligent Home”. *International Journal of Computer Science and Network Security, Vol. 7, No. 5, May 2007.*
- [5]. A. Delgado, R. Picking and V. Grout, “Remote-Controlled Home Automation Systems with Different”, *Centre for Applied Internet Research (CAIR), 2006.*