



## NEURAL NETWORK AND FUZZY SYSTEM

<sup>1</sup>Dr. PawanWhig, <sup>2</sup>S. N Ahmad  
Dean Research, VIPS<sup>1</sup>, Professor in JMI<sup>2</sup>

### ABSTRACT

The present study provides integrated knowledge on the neural network and fuzzy system. The fundamental concept and component of the system along with its properties. The hybridization of neural network and fuzzy system are proving tremendous impact in solving various problems. Hence the basic aim of the present study is to provide insight on the basic characteristics and hybridization of these two techniques and illustrates the neural nets, neuro-fuzzy process and its schemes.

**Keywords:** *Neural network, fuzzy system, hybridization, logic system*

### NEURAL NETWORK AND FUZZY SYSTEM

There is a basic concept about the neural system, that neural network concentrate on the structure of the human brain, like on the hardware, copying the fundamental functions, and on the other hand fuzzy logic system concentrate on the software copying fuzzy and symbol-based reasoning. The neuro-fuzzy approach contains many different connotations[1-3].

#### Fundamental concepts of neural networks and fuzzy logic systems

Fuzzy logic and neural networks systems are generally considered as part of the soft computing area-

#### SOFT COMPUTING

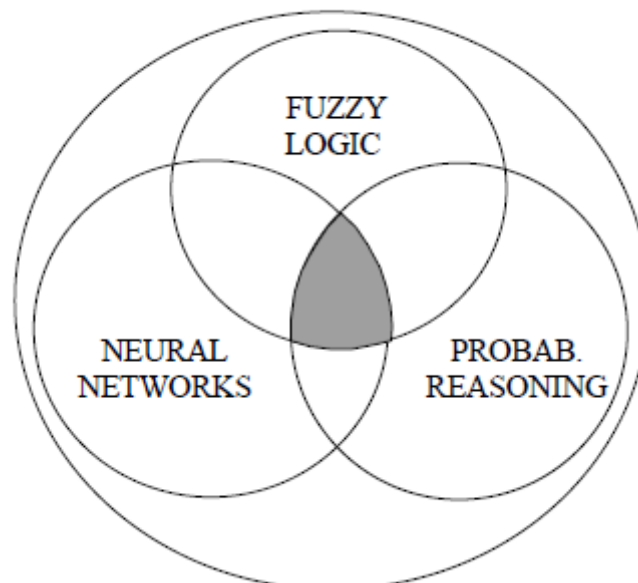

Soft computing as a composition of fuzzy logic, neural networks, and probabilistic reasoning. Intersections are included are Neuro-fuzzy system and technique. Approaches for the probabilistic to the neural networks, specifically classification networks and fuzzy logic systems And reasoning related to the Bayesian [3,4].

**There are some important quality of the fuzzy logic following are**

In the fuzzy logic, exact reasoning is shown as the limiting case of the proper reasoning.

In this logic, everything is a matter of degree. In the fuzzy logic, knowledge is explained as an elastic collection or, identically, fuzzy constraints on the variables collections. The conclusion is viewed as the process of the propagation of the constraints elastic. And any type of logical system can be fuzzified. There are two types of main qualities of the fuzzy systems which provide them better work performance for the significant applications. Fuzzy systems are more suitable for uncertain or proper reasoning, especially for the system with a mathematical model that is typical to derive [1-5].

Fuzzy logic permits decision making with the approximated values under the incomplete or uncertain type of information [6]. Artificial neural systems can be managed as the simplified mathematical model of the brain such as systems and they perform the functions as the parallel distributed computing networks. This can be extracted from the emerging role of artificial intelligence which are gaining popularity in recent years [7] But, in contrast to the conventional computers, that are programmed for performing a significant task, more of the neural networks should be taught or provide training. They can also learn advanced associations, innovative functional type dependencies, and new patterns.

But the most essential benefits of the neural networks are their adaptivity quality. this network can automatically adjust their weights for optimizing their behavior as the identifiers patterns, system controllers, decision-makers and predictors, etc. the adaptivity permits the neural network to perform well even though when the system or the environment being controlled and varies across the time. There are many of the control issues which can provide advantages from regular nonlinear adaption and modeling [6,8]. When the fuzzy logic did the task a concluded mechanism under the cognitive uncertainty, a neural network that is based on the computation provides offers like exciting benefits, like adaption, learning, parallelism, fault tolerance, and normalization.

Skills		Fuzzy systems	Neural nets
Knowledge accession	Tools for input	Interactions for human experts	Algorithms for sample sets
Uncertainty	Cognition Information	Decision making Qualitative and quantitative	Perception Quantitative
Reasoning	Speed of mechanism	Heuristic search law	Parallel computation high
Adaption	Learning about fault	Low induction	Too high adjusting

	tolerance		weights
Natural language	Flexibility for implementation	Explicit high	Implicit flow

**PROPERTIES FOR FUZZY SYSTEMS AND NEURAL NETWORKS**

For enabling the system to deal with the perceptual uncertainties in the manner more such as humans, in this one maybe incorporate the idea of the fuzzy logics into the neural networks. The outcome hybrid systems are named fuzzy neural, neuro-fuzzy, neural fuzzy, or fuzzy neuro network. Neural networks are utilized to strain the membership of the functions of the fuzzy systems which are employed as the decision making systems for handling tools. Even though fuzzy logic can also encode the knowledge of the expert directly to utilizing the rules with the linguistic labels, it generally takes more time for designing and tune the membership functions that quantitatively define these linguistics labels. Neural network techniques for learning can automate this process and significantly reduce the time of the development and cost when improving the performance [9]. this is found that neural networks and fuzzy systems are similar in which they are changeable. So far in the practice, each has it is their benefits and disadvantages. For the neural networks, the knowledge is automatically needed by the backpropagation algorithm, however, the learning process is slow and examination of the trained network is typical (black box). Neither this is possible to retrieve the structural knowledge from a trained neural network, nor can they combine specific information about the issues into a neural network in context to simplify the learning process. collaborative approaches utilize the neural networks to optimize the fixed parameters of a normal fuzzy system, or the preprocess data and retrieve fuzzy rules from the data. The fundamental processing tools of the neural networks are named the artificial neurons, or simple neurons. Signal flow from the neuron inputs  $X_j$  is considered as the unidirectional and these are indicated by the arrows, as the neuron's output flow of the signal. According to the figure, consider an easy neural net, all the signals and weights are actual numbers. Input neurons don't change input signals, therefore their outcomes are similar to their input. The signal  $x_i$  is interrelated with the weight  $w_i$  to generate the product  $p_i = w_i x_i, i=1, \dots, n$ . the information about the input  $p_i$  is aggregated through combination to create the input is

$$net = p_1 + \dots + p_n = w_1 x_1 + \dots + w_n x_n$$

for the neuron. Neuron utilizes its transfer function  $f$ , this could be a sigmoidal function.

$$F(t) = 1 / (1 + e^{-t})$$

Output is get-

$$y = f(net) = f(w_1 x_1 + \dots + w_n x_n).$$

This is the easy neural net, that performs addition, multiplication, and sigmoidal  $f$  will be named as the continue or the standard neural net [10-12].

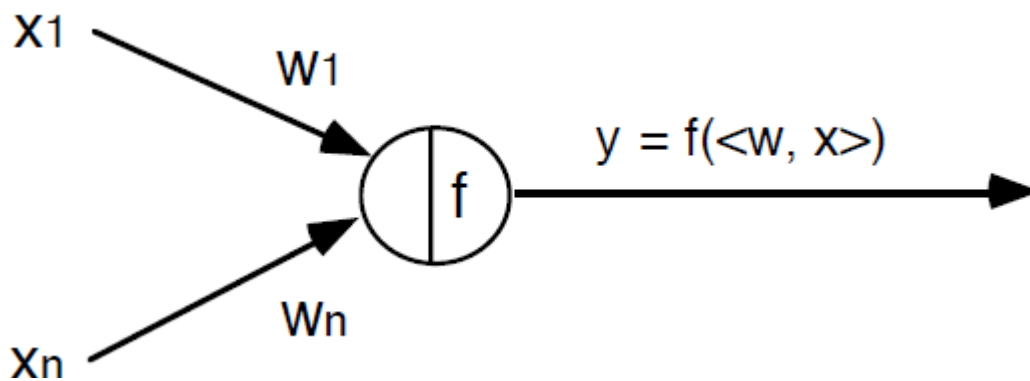

### EASY NEURAL NETWORK

If perform another type of operations such as t-norm, or a t-conom, to add incoming data with a neuron acquire what call a hybrid neural net. These changes guide to the fuzzy neural framework based on the fuzzy arithmetic operations. A hybrid neural net maybe not in use for multiplication, sigmoidal, and additional function. The results of these operations are not important are in the unit interval.

A hybrid type neural net is the neural net with the crisp the signals, weights, and crisp transfer the function. But

1. This can be combine xi and utilizing a t-norm, t-conom, or a few other regular operations.
2. This can be aggregate the pi's with the t-norm, t-conom or any other type regular functions
3. F is any regular function from the input to the outcome.

There is the emphasis here in which all the inputs, results and the weights of the hybrid neural net is actual numbers taken from the interval of the unit (0, 1). Element related to the process of a hybrid neural net is named fuzzy neuron[9-11]. This is known nicely that continuous nets are the universal approximators like those are all approximate the regular function on the compact sets to the accuracy for the arbitrary. In the discrete fuzzy system fro expert one of the inputs a discrete the approximation to the fuzzy sets and acquires a discrete the approximation of the outcome fuzzy set. Generally, discrete fuzzy expert systems and controllers are the regular mappings. So this is concluded which provide a regular fuzzy expert system, or regular fuzzy controller, this is the continuous fuzzy controller, this is the continuous fuzzy controller, this is a continuous net which can be constant proper it to any of the degrees of the correctness on the compact sets [13]. The issue with this outcome is nonconstructive and doesn't tell about how to develop the net. Directly fuzzification of the conventional neural networks is to expand the connection weight and inputs and fuzzy desired outcomes to the fuzzy numbers. These all extensions are summarized in the below table.

Fuzzy neural net	Weights	Inputs	Targets
Type 1	Crisp	Fuzzy	Crisp
Type 2	Crisp	Fuzzy	Fuzzy

Type 3	Fuzzy	Fuzzy	Fuzzy
Type 4	Fuzzy	Crisp	Fuzzy
Type 5	Crisp	Crisp	Fuzzy
Type 6	Fuzzy	Crisp	Crisp
Type 7	Fuzzy	Fuzzy	Crisp

**DIRECT FUZZIFICATION OF NEURAL NETWORKS**

Fuzzy neural networks of type 1 are utilized in the classification issues of the fuzzy input vector to the crisp class. Networks of type 2,3, and 4 are utilized to execute fuzzy IF-THEN rules. But, the last three types in the table are not realistic.

1. In type 5, outcomes are always actual numbers because of both inputs and weights are the actual numbers.
2. In type 6 and 7, the weights fuzzification is not essential because targets are the actual numbers[12-14].

Continual fuzzy networks are a neural network with the fuzzy signal and fuzzy weights, sigmoidal type transfer function, and all operations are defined by the Zadeh's extension principle. Also, consider an easy continue fuzzy neural net in below figure-

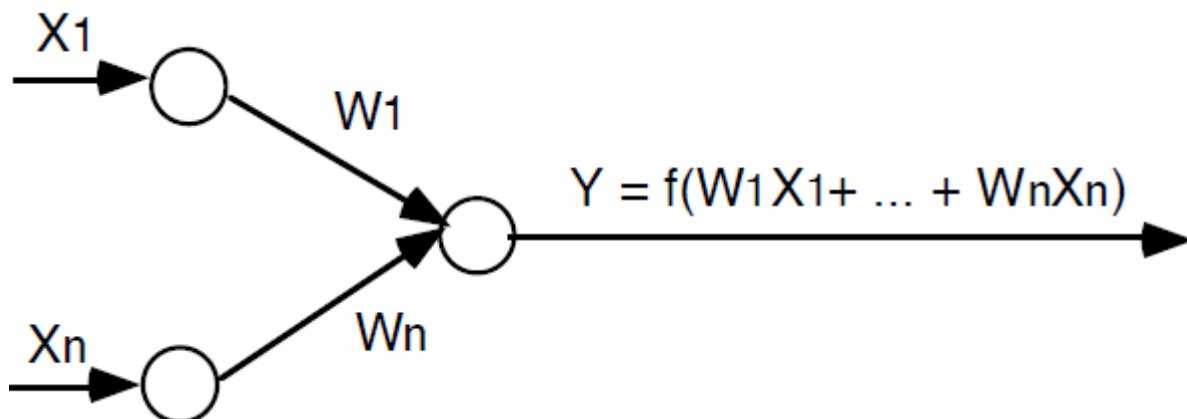

Easy fuzzy neural net

All the weights and signals are the fuzzy numbers. The inputs neurons don't modify the input signals, therefore there is a result that is similar to their inputs. The signal  $X_i$  is interacted with weight  $W_i$  to generate the product  $P_i = W_i X_i, i = 1, \dots, n$ .

For this utilize the extension principle for computing  $P_i$ . The information for input  $P_i$  is the aggregated, through the standard extension combination to create the inputs

$$net = P_1 + \dots + P_n = W_1 X_1 + \dots + W_n X_n$$

for the neuron. Neuron utilizes its transfer functions  $f$ , which is a sigmoidal function, for computing the results.

$$Y = f(\text{net}) = f(W_1X_1 + \dots + W_nX_n)$$

Where the f is a sigmoidal function and membership function of results of the fuzzy set Y is calculated through the principle extension.

The disadvantage of the continual fuzzy neural network which they are not the universal approximators. So should abandon the principle of the extension. If they are to acquire a universal approximator.

### ARTIFICIAL NEURAL NETWORK

Artificial neural network systems are considered as the easiest mathematical models for the brain such as systems and they also done functions as the parallel distributed computing networks. The knowledge is in stable state form or also mapping the embedded in the networks which can be recollected in the response to the presentation of the cue.

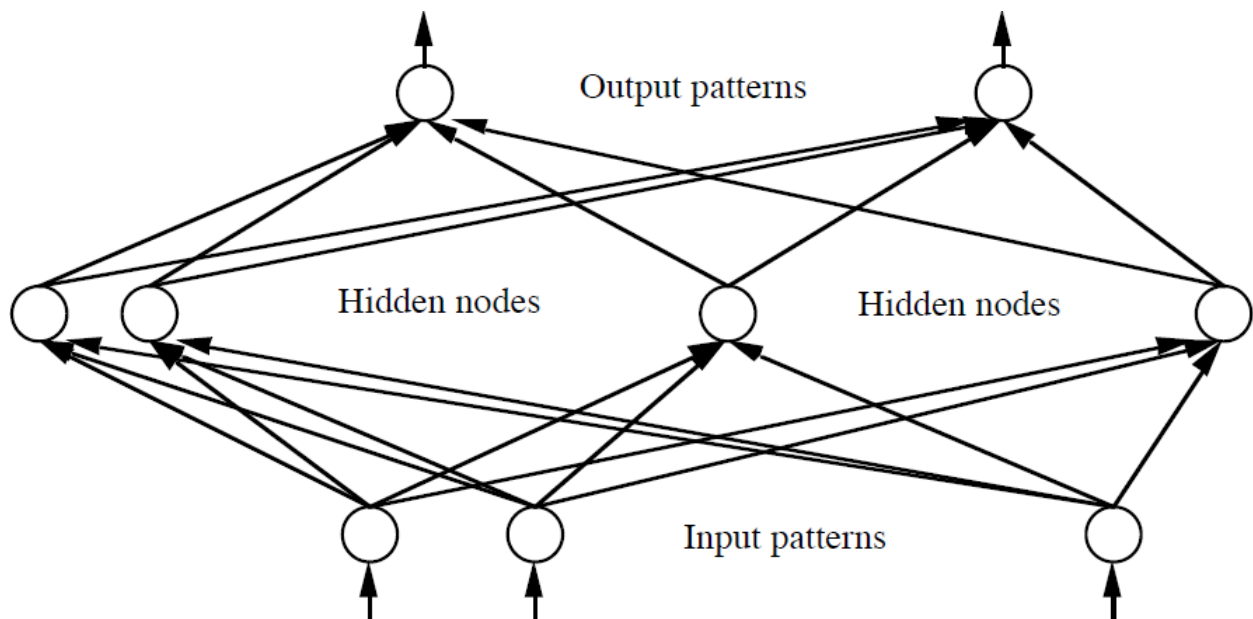

E-ISSN NO:2349-0721

### MULTI-LAYER FEED-FORWARD NEURAL NETWORK

The fundamental processing components of the neural networks are named the artificial neurons, or easily neurons or the nodes. Every processing unit is characterized through a level of activity, this represents the polarization state of the neuron, a value for output this represents the firing rate of the neuron. Set of the input connections, representing the synapses on cell and its dendrite, bias value represents an internal level of resting for the neuron, and some set of the outcome connections also represents the axonal projections [13-15]. Every one of these attributes related to the unit is represented mathematically through the actual numbers. So, every connection has been a related weight, synaptic strength that fixes the impact of the input which is incoming on the activation unit level. Some times weights may be positive or negative.

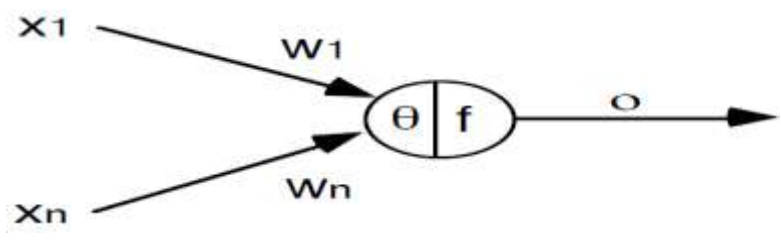

## PROCESSING ELEMENTS WITH ONLY OUTPUT CONNECTIONS

The flow of signal from the neuron inputs  $X_j$  is considered to be as the unidirectional and indicated by the arrows, this is the neuron output signal flow. And the neuron signal output is provided by the following relationship.

$$o = f(\langle w, x \rangle) = f(w^T x) = f(\sum_{j=1}^n w_j x_j)$$

(n

j=1

$w_j x_j$ )

where  $w = (w_1, \dots, w_n)^T \in \mathbb{R}^n$  is the vector related to weight. The function  $f(w^T x)$  is generally referred to as the activation or the transfer function [9-11]. It is the domain set of the activation values, neuron model net, so generally utilize this function as  $f(\text{net})$ . The net of the variable is defined as the scalar weight product of the input vectors and weight.

$$\text{net} = \langle w, x \rangle = w^T x = w_1 x_1 + \dots + w_n x_n$$

where  $w = (w_1, \dots, w_n)^T \in \mathbb{R}^n$  is weight vector. The function  $f(w^T x)$  is generally referred to as the activation function.

$$\text{net} = \langle w, x \rangle = w^T x = w_1 x_1 + \dots + w_n x_n$$

$$o = f(\text{net}) =$$

$$1 \text{ if } w^T x \geq \theta$$

$$0 \text{ otherwise,}$$

159

## CONCLUSION

The concept of neural network with its basic principles was presented in the study to integrate its component for the improvement of existing applications. Further studies will be interesting enough in this area to get more precise and advances in this field.

## REFERENCES

1. Alonso, J. M., Castiello, C., & Mencar, C. (2015). Interpretability of fuzzy systems: Current research trends and prospects. In *Springer handbook of computational intelligence* (pp. 219-237). Springer, Berlin, Heidelberg.
2. Pawan Whig and S. N. Ahmad (2014), Development of Economical ASIC For PCS For Water Quality Monitoring, *Journal of Circuit System and Computers*, Vol. 23, No. 6, pp: 1-13
3. Wu, S., & Er, M.J. (2000). Dynamic fuzzy neural networks-a novel approach to function approximation. *IEEE transactions on systems, man, and cybernetics. Part B, Cybernetics*: a publication of the IEEE Systems, Man, and Cybernetics Society, 30 2, 358-64.
4. Rong, H., Ye, X., & Xiang, X. (2015). A Self Adaptive Incremental Learning Fuzzy Neural Network Based on the Influence of a Fuzzy Rule. *2015 International Conference on Intelligent Information Hiding and Multimedia Signal Processing (IIH-MSP)*, 354-359.

5. Zhang, D., Han, Q. L., & Jia, X. (2015). Network-based output tracking control for T-S fuzzy systems using an event-triggered communication scheme. *Fuzzy sets and systems*, 273, 26-48.
6. Lin, C., & Lu, Y. (1996). A neural fuzzy system with fuzzy supervised learning. *IEEE transactions on systems, man, and cybernetics. Part B, Cybernetics : a publication of the IEEE Systems, Man, and Cybernetics Society*, 26 5, 744-63 .
7. Rahul Reddy Nadikattu. 2016 THE EMERGING ROLE OF ARTIFICIAL INTELLIGENCE IN MODERN SOCIETY. *International Journal of Creative Research Thoughts*. 4, 4 ,906-911.
8. Leng, G., Prasad, G., & McGinnity, T.M. (2004). An on-line algorithm for creating self-organizing fuzzy neural networks. *Neural networks : the official journal of the International Neural Network Society*, 17 10, 1477-93 .
9. Saneifard, R. (2011). Some properties of neural networks in designing fuzzy systems. *Neural Computing and Applications*, 21, 215-220.
10. Liu, F. (2010). Design for self-organizing fuzzy neural networks based on adaptive evolutionary programming. *2010 2nd International Conference on Advanced Computer Control*, 3, 251-254.
11. Leng, G., McGinnity, T.M., & Prasad, G. (2006). Design for Self-Organizing Fuzzy Neural Networks Based on Genetic Algorithms. *IEEE Transactions on Fuzzy Systems*, 14, 755-766.
12. Qiao, J., & Wang, H. (2008). A self-organizing fuzzy neural network and its applications to function approximation and forecast modeling. *Neurocomputing*, 71, 564-569.
13. Dahal, K.P., Almejalli, K., Hossain, M.A., & Chen, W. (2015). GA-based learning for rule identification in fuzzy neural networks. *Appl. Soft Comput.*, 35, 605-617.
14. Liu, F., & Er, M.J. (2012). A Novel Efficient Learning Algorithm for Self-Generating Fuzzy Neural Network with Applications. *International journal of neural systems*, 22 1, 21-35 .
15. Pawan Whig and S. N. Ahmad, (2014) "Simulation of Linear Dynamic Macro Model of Photo Catalytic Sensor in SPICE" *Compel, the international journal of computation and mathematics in electrical and electronic engineering*, Vol. 33 No. 1/2.
16. Xiao-hui, Z., & Yi-bing, S. (2014). Optimization and Implementation of Self-Organization Fuzzy Neutral Network Control Algorithm. *The Open Automation and Control Systems Journal*, 6.