

## ANALYSIS OF WATER SUPPLY SYSTEMS OF CEMENT MANUFACTURING ENTERPRISES

<sup>1</sup>Gadaev Abror Niyazovich, <sup>2</sup>Abilov Elyor Ermamatovich

PhD, Professor of the Samarkand State architectural and civil engineering institute, Republic of Uzbekistan<sup>1</sup>,  
Doctoral student of the Samarkand State architectural and civil engineering institute, Republic of Uzbekistan<sup>2</sup>

### ANNOTATION

This article analyzes the data on the growing demand for water in the cement industry. There is also information about the role of water in the production of Portland cement by the "dry" method. Additional details on the balance of water consumption in cement plants, use in the main technological and other facilities are covered. At the end of the article, recommendations for optimizing water consumption based on the prospects and analytical results of water use in cement plants are given.

**Keywords.** *Cement production plants, Production of Portland cement by "dry" method, water consumption for drinking and household purposes, technological water, fire water supply system, optimization of water consumption.*

### PROBLEM. ANALYSIS. RESEARCH.

Today, the main raw material in the construction industry is cement. The difficult economic situation caused by the COVID-19 pandemic has caused significant problems in industry as well as in all other sectors. There are objective and subjective reasons for this. During the pandemic, the construction industry was one of the first to begin its work in "limited and tight control zones." Of course there are issues of complexity. One of them is the control of water sources, water supply and sewerage, and its safe operation. Despite the global pandemic, the scale of construction in the world is expanding, so the need for cement, one of the main building materials, is growing and the industry is developing. This analytical article presents the results of scientific research on water problems in the cement industry, the creation of water supply systems that meet environmental requirements. First of all, let's talk briefly about the scale of the cement industry and its place among other industries.

Cement production in the Republic of Uzbekistan in 2020 amounted to 12,537.4 thousand tons (114.1% more than in 2019) [1]. As the number of cement plants increases, so does their demand for fixed resources. Demand for water, one of the main natural resources, is growing in an industrial scale. If the whole water management system is considered as a single complex and takes into account the possible changes in existing natural conditions, the negative consequences of its design on the basis of long-term forecasting of water demand for quantity and quality of various sectors of the economy are negligible. can be ensured. Analysis of the composition of water consumption of cement plants allows to assess the water demand of the developing industry.

The main factor in the evaluation of cement plants is the cost of production. This makes the choice of "dry" or "wet" method of production the main issue. There are several methods of Portland cement production: water-saving technology, namely water-saving "dry" method of cement production. Production of 1 ton of cement / clinker by the "dry" method saves 35-40% of all types of energy [4]. Water-saving technologies help to reduce the environmental impact of industrial enterprises, that is the negative impact on production of water bodies. Currently, the share of "dry" cement is 80% in Japan, 55% in the United States and 90% in Germany. The share of cement obtained by this method in our country is 50% [5]. The water balance of cement plants can be summarized as follows:

$$Q_{ms} + Q_{ap} = Q_t + Q_{dh} + Q_{fire} + Q_{other}$$

$Q_{ms}$  - amount of water from the main source (from surface and groundwater sources) m<sup>3</sup>;

$Q_{ap}$  - the amount of water collected as a result of atmospheric precipitation (in very small proportions, but present);

$Q_t$  - m<sup>3</sup> of water used for technological needs (up to 74% of water consumption at the cement plant [6]);

$Q_{dh}$  - the amount of water used for drinking and household needs. (Water quality is regulated by UzDSt 950 ÷ 2011) m<sup>3</sup>;

$Q_{fire}$  - the amount of water required for firefighting m<sup>3</sup>;

$Q_{other}$  - the amount of water used for other needs of the enterprise;

To clearly understand the essence of the above equation, we present the scheme of the water supply system of the cement plant.

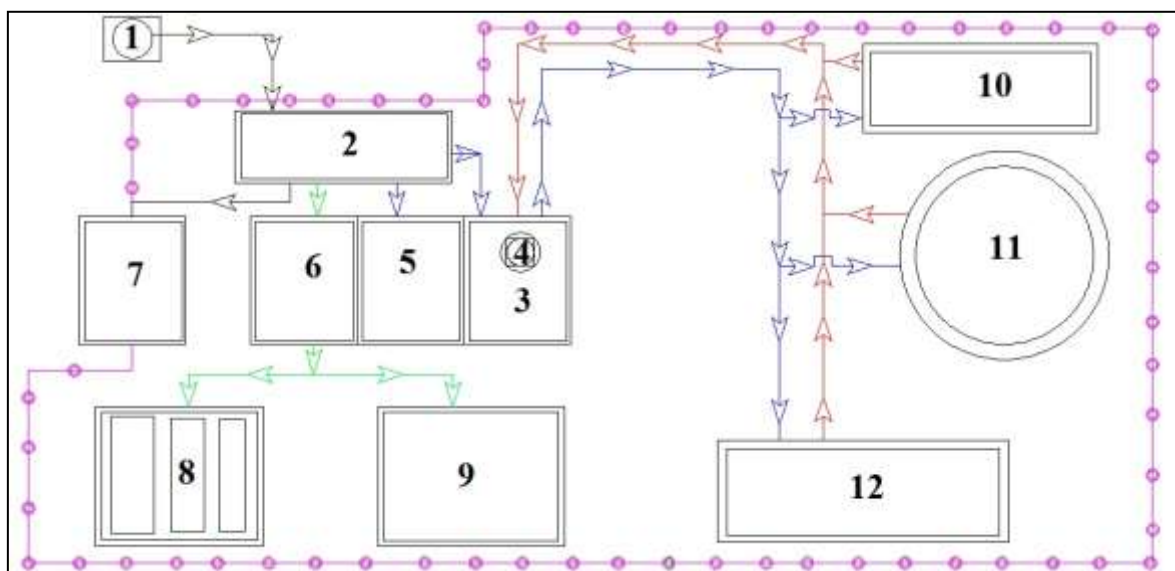

**Figure 1. General scheme of water supply system of cement plants.**

1- main water source, 2- Chemical water treatment and pumping station, 3- Technological water capacity, 4- Graduation, 5- Technological water reserve capacity, 6- Drinking water supply, 7 - Fire-fighting water storage capacity, 8-Staff dining and living quarters, 9-Landscaping (landscaping, gardens, etc.), 10-Raw materials shop, 11-Burning shop, 12- Crushing shop.

- water supply system from the source;
- technological cold water system;
- heated process water system;
- drinking water system;
- fire-fighting water supply system;

We take a separate approach to each system to optimize water consumption in cement plants. The first category of systems is a system that serves to transfer heat using a heat exchanger in water equipment and products when using water for technological purposes, in which the water temperature rises but is not polluted [7]. In industrial enterprises specializing in the production of Portland cement by the "dry" method, water is mainly not in direct contact with raw materials, semi-finished products, goods or is not involved in transportation. Used only for cooling equipment. Therefore, it is advisable to use a closed system in the process water supply of the enterprise. This system provides cooling and return of water for production. There are certain losses in the amount of water during cooling. During the cooling process, the water used in the leakage filling system must undergo chemical treatment. If the quality of water from the source is close to the required standards, it will save on processing costs. Water used for drinking and household needs is mainly used for the needs of workers. Depending on the number of employees, the number of shifts, the number of shower trays for washing, the maximum daily water consumption time is selected and the system is hydraulically calculated for this time. This is because the maximum water consumption time is considered to be the time to check the reliability and continuous operation of the system. If housing facilities are built on the territory of the enterprise, the share of drinking water consumption in the total water consumption will increase significantly. The water supply required for firefighting is mainly stored in special basins. Its minimum amount is the volume of water that must be stored in accordance with the category of fire safety of buildings, the number of fires and the probability of their occurrence, the continuous operation time of the firefighting system (assuming the operating time of fire hydrants is 3 hours [8]) should be determined. Unplanned but probable water consumption may also occur on the site. This is mainly due to the climatic conditions of the place and its geographical location. Today, companies are expanding their "green areas". For this purpose, along with landscaping, landscaping, greenhouses and auxiliary farms are being created. It is advisable to use the water that can be collected from precipitation for these subsidiary farms. The use of water-saving technologies in the use of these waters meets today's modern requirements. Rainwater is collected in special storage tanks and can be used to irrigate plants after initial treatment. This method reduces the consumption of water from the main water source [9]. It usually saves up to 10% of total water consumption based on annual rainfall. Saving water contributes to the programmatic implementation of the difficult environmental situation in the region [10]. This, in turn, corresponds to the principles of formation of alternative sources of water and its sustainable use [13].

### **CONCLUDING RECOMMENDATION**

Receiving cement in a "dry" way at cement plants allows for a sharp reduction in overall energy consumption, including water consumption. Water is mainly used for technological needs, because water is used for cooling purposes, it is not damaged and reuse can be achieved with less resources. Separate design of drinking and fire-fighting water supply system to save costs for the preparation of drinking water in accordance with the requirements of UzDSt 950 ÷ 2011, as well as landscaping, horticulture, greenhouses basic water consumption can be reduced by irrigation through rainwater. The fire water reserve allows to save up to 35% of drinking water when the storage capacity is separate from the domestic drinking water network. This is recommended for the Sherabad cement plant, whose main source of water is groundwater. Because it is not only convenient but also saves water resources [12].

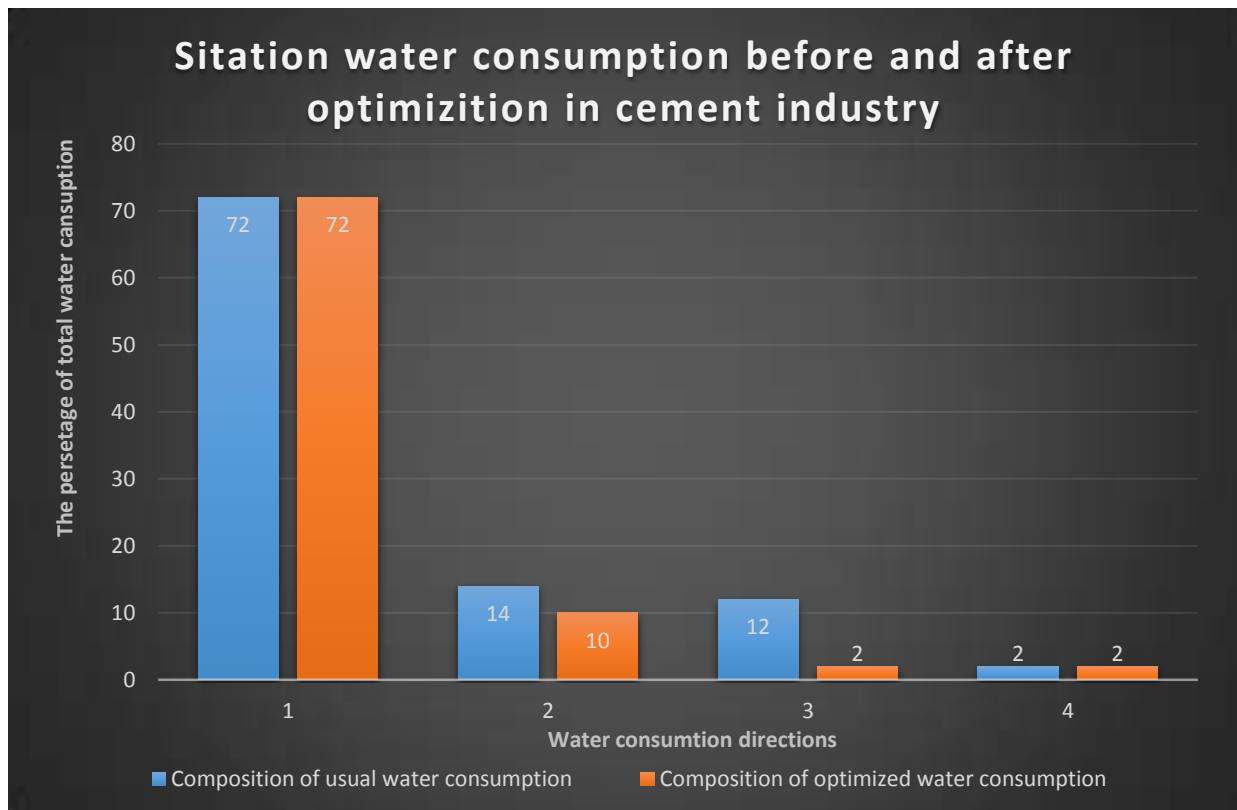

**Figure 2. 1- technological water consumption, 2- economic-drinking water consumption, 3- irrigation water consumption, 4- other water consumption**

In the diagram above, their approach to the use of water resources based on modern technologies is consistent with the principle of sustainable development and leads to the conservation of material and natural resources. The optimization of water consumption in the cement plants under study in this article provides a comprehensive solution to the water needs of the developing industry and sustainable development of the enterprise.

## REFERENCES

- [https://uzsm.uz/uz/press\\_center/news/2020-yilda-qurilish-materiallari-sohasida-jami-22-0-trln-so-mlik-mahsulotlar-ishlab-chirdi/](https://uzsm.uz/uz/press_center/news/2020-yilda-qurilish-materiallari-sohasida-jami-22-0-trln-so-mlik-mahsulotlar-ishlab-chirdi/)
- V. X. Inoyatovich. Nature protection and rational use of its resources. Textbook. Tashkent - 2010. Page 80.
- Ilyin D.V., Verdiyev M.A., Nesmeyanov N.P. Complex technological safety of cement plants // Bulletin of the Belgorod State Technological University named after V.G. Shukhov. 2013. № 5. Pages 83–86.
- I. A Rybiev. Construction materials science: a textbook for construction special universities. Graduate School. Moscow-2003. Page 788
- Khoshimkhanova M.A. Methods for the analysis of finished products, semi-finished products and raw materials in the production of cement "dry". Bulletin of Science and Education No. 10 (88). Part 2. 2020. Pages 29-31.
- A technical reference guide to the best available technology. ITS6-2015. "Cement production". Moscow Bureau NDT-2015. Page 294

7. V. B. Gusakovskiy, E. E. Vuglinskaya. Industrial water supply. Tutorial. Saint Petersburg 2016. Page 10
8. QMQ; 2.04.01 - 98. Tashkent 1998. Page 13.
9. G. A. Selitsky, E. A. Ulasovets, D. B. Ermakov. Industrial and storm wastewater treatment technology for use in the circulating water supply system of a mining and metallurgical enterprise. Water management of Russia №4, 2008, page 60.
10. Michael R. Edelstein, Astrid Cerny, Abror Gadaev. Disaster by Design: The Aral Sea and its Lessons for Sustainability. 2012 ISBN: 978-1-78190-375-9 UK, North America (USA and Canada), Japan, India, Malaysia, China
11. Abror N. Gadaev, Daniyar K. Jumamuratov “Urgent Central Asian water challenge: Sustainable Water Resources Management” <https://karsu.uz/en/journal-2020-2/>
12. Gadaev. A. N, Abilov E.E “Water problems and prospects of solutions of industrial enterprises in Surkhandarya region”. Proceeding of International Conference on Reserch Innovation In Multidisciplinary Sciences, 2021.Hosted From New York USA. Pages 209-212.
13. Gadaev A.N., Jumamuratov D.K., Yasakov Z.X., Saidov S.S. Generalized technology of alternative rainwater use in order to save water resources. Journal of Advances in Engineering technology. 2020 Vol 1. № 2pp. 51-53 / DOI 10.24412 / 2182-1431-2020-2-52-53

