

SEMI-AUTOMATIC DISHWASHER

¹Dhure Pranav Prasad, ²Gaikwad Amit Ravikant, ³Patil Amol Sanjay, ⁴Tungare Machindranath Rajan,
⁵Prof. Anand Kumar Singh

B.E. Mechanical ARMIET Thane, India^{1,2,3,4}, Asst. Prof. Mechanical ARMIET Thane, India⁵
pranav.dhure007@gmail.com¹, amitgaikwad164@gmail.com², amol8364@gmail.com³,
machindra174@gmail.com⁴

ABSTRACT

This paper discusses how to reduce human efforts in dishwasher. The dishwasher has made cleaning and drying dishes much easier and more efficient. This paper also discusses the problems faced in usage of Automatic Dishwasher and solutions on those problems. Automatic dishwasher uses large amount of energy, time and is costly. And being costly, the usage of automatic dishwasher in our country is very less. By using semi-automatic dishwasher, we can reduce time as well as human efforts significantly. Also by using plastic material for casing part, the overall weight of the assembly is also reduced. By separating assembly in 3 parts for washing of dishes, rinsing of dishes and washing of glasses, large amount of work can be done in considerably lesser time. In conventional dish washing process large amount of human power as well as quantity of water is used. So keeping that in mind, to reduce this Semi-Automatic dish washer is developed. Also we can use this in places where there is vast use of dishes for example, marriage ceremony. This dishwasher is useful for household use, which can save time and cost rather than spending in washing dishes by hand and wasting large amount of energy.

INTRODUCTION

Washing dishes is most commonly done activity in the world, in most of families people wash dishes by hand which is straining to muscles and detergent is chemically harmful.. As far as manual process is concerned in houses of India, washing is done by hand scrubbing which is straining to the muscles through its energy and postural requirements. It may also lead to clinical, anatomical disorders and back pain which may affect the operator's health. Many of their household chores are performed by the women and some can be very physically challenging and time-consuming. So in several ways in which we can improve their lifestyle, and one aspect that we can improve on is the way they wash their dishes. Currently the chore of washing performed by the women, and can be very labour intensive as it is done for up to several hours each week.

The same can be experienced in marriage ceremony with caterers. In today's world of Automation Era it is barely possible to find any field that implemented atomization which reduces Human effort, improves Production rate and also increases Efficiency. Then it could be the biggest manufacturing industry, Pharmaceutical industry, Hospitality field and even Household or Kitchen automation. Maintaining the Integrity of the Specifications

The template is used to format your paper and style the text. All margins, column widths, line spaces, and text fonts are prescribed; please do not alter them. You may note peculiarities. For example, the head margin in this template measures proportionately more than is customary. This measurement and others are deliberate, using specifications that anticipate your paper as one part of the entire proceedings, and not as an independent document. Please do not revise any of the current designations.

NEEDS

Washing dishes is not the most rewarding task. Cooking can be creative, but cleaning up afterward seems like a waste of time and leaves the person washing complaining about "dishpan hands." Most conventional dishwashers installed in U.S. households today use 7-14 gallons per load and account for less than 2 percent of

the water used in an average American home. Despite the small portion of overall water consumption by dishwashers, newer machines are substantially more water- efficient than older models. Today the most efficient (full-size) machines use a maximum of 7 gallons per load - and some as little as 4.5 gallons. Energy savings also result from upgrading to an efficient dishwasher because fewer gallons of water need to be heated per cycle. Many new dishwashers feature microprocessor-controlled, sensor-assisted wash cycles that adjust the wash duration to the quantity of dirty dishes or the amount of dirt in the rinse water. This can save water and energy if the user runs a partial load.

BLOCK DIAGRAM

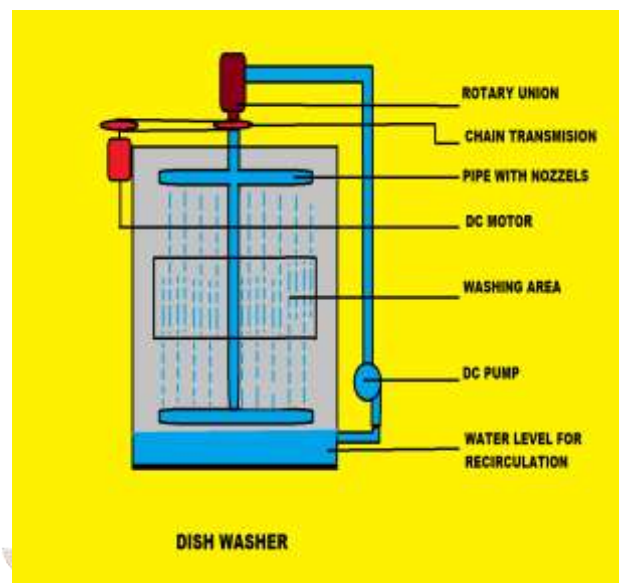

FIG. BLOCK DIAGRAM

WORKING

The title semi-automatic is because it involves both the machine work with very less human effort. The design will consist of one rectangular plastic casing and will be divided into 3 compartments. → The very first compartment will contain the dish, cutlery or crockery utensil's cleaning. This compartment will be filled with detergent water up to 50% height to avoid splashing. There will be two rotating brushes with negligible clearance between them. A stand will be fixed at the bottom so that the dishes can rest on it and there will be no need to hold the dishes while they are being washed. → The second compartment which is middle one will function same as that of first one. The only difference is that this compartment will be filled with clean water for rinsing the detergent, and instead of rotating brushes, rotating sponges will be fixed at both the sides of the dishes. So that there won't be any possibility of food stains or detergent remnants on the dishes. → The third and last compartment will comprise again detergent water, but now for the glass cleaning. This compartment will contain inner rotating brush and outer fixed brush. → And to rotate all this brushes there will be single motor shaft which will be mounted with 4 pulley for belt drive. 2 pulleys to drive 2 rotating brushes in first compartment, 2 pulleys to drive 2 rotary brushes in second compartment and at the end of a bevel gear to drive the vertical rotary brush in third compartment.

CALCULATION

- SELECTION OF MOTOR

We know,

$$\text{Power} = \frac{2\pi NT}{60000}$$

Where,

P = Power in kW,

N = Speed in rpm,

T = Torque in Nm

We have,

Torque = Force x Perpendicular distance

Where,

Force = (Load applied on the rack + Mass of shaft) x Gravitational force

Let, the average load applied on the rack will be 10kg, the mass of rack will be 4kg and mass of shaft be 1kg. We get, Force = (10 + 4 + 1) x 9.81 = 147.15N

Perpendicular distance = 20cm = 0.2m

Torque = 147.15 x 0.2 = 29.48

$$\text{Now, Power} = \frac{2\pi NT}{60000}$$

$$= \frac{2 \times 3.14 \times 20 \times 29.48}{60000}$$

$$= 0.0771 \text{ kW} = 0.10 \text{ hp}$$

Therefore, select standard motor as 0.5hp.

- DIMENSIONS OF DISHWASHING MACHINE

The entire body of dishwasher that is outer surface was made of metal sheet which is of dimension,

Length=70cm, Height=60cm and Width= 70cm.

Volume of dishwasher = 70 x 60 x 7 = 294000cm³

DIMENSIONS OF WATER STORAGE TANK

The entire body of water storage tank is made of plain sheet G.I. which is of dimension,

Length = 70cm, Height = 50cm and Width = 5cm.

Volume of Water storage Tank = 70 x 50 x 5 = 17500 cm³ = 17.5 liters

- DIMENSIONS OF RACK

Height of the rack = 50cm = 0.5m

Diameter of outer ring = 45cm = 0.45m

Area of outer ring $A = 0.1590\text{m}^2$

Diameter of inner ring = 15cm = 0.15m

- ELECTRICITY CONSUMPTION

Given Powers

Pump = 0.3875 KW = 0.5 hp

Metal Heating Element = 2 KW

Dispenser = 0.025 KW

Total Power Used = 0.3875 + 2 + 0.025 = 2.39785

For 5 Plates,

$$\text{Power} = \frac{2.39785 \times (45+30)}{3600} = 0.04995 \text{ KW}$$

$$\text{Power} = \frac{2.39785 \times (45+60)}{3600}$$

$$= 0.06993 \text{ KW}$$

For 15 Plates,

$$\text{Power} = \frac{2.39785 \times (60+90)}{3600}$$

$$= 0.0999 \text{ KW}$$

For 20 Plates,

$$\text{Power} = \frac{2.39785 \times (100+120)}{3600}$$

$$= 0.1465 \text{ KW}$$



DESIGN OF SHAFT

Terms used:-

T= Twisting moment (or torque) acting on shaft.

J= polar moment of inertia (polar MI) of shaft about axis of rotation.

τ = Tensional shear stress N/mm².

L= Length of shaft in “mm”.

P= power transmitted in KW.

Shaft subjected to twisting moment only,

$$T/J = r$$

For solid shaft,

$$T = \frac{\pi}{32} d^4$$

$$T = \frac{\pi}{16} d^3 \times \tau$$

.....EQ 1

Also,

$$\text{Power (P)} = 2\pi \times NT/60$$

$$1.49 \times 10^3 = 2\pi \times 300T/60$$

$$T = 47.7110^3 \text{ N.mm}$$

Taking shear stress value from design data book,

$$= 32 \text{ N/mm}^2 \text{ OR MPa}$$

Using strength equation from equation (1),

$$T = /16 d^3 \times \tau$$

$$23.7110^3 = /16 d^3 \times 32$$

$$d = 18.65 \text{ mm} \approx 20 \text{ mm (say)}$$

For safe design we take it as 20mm.

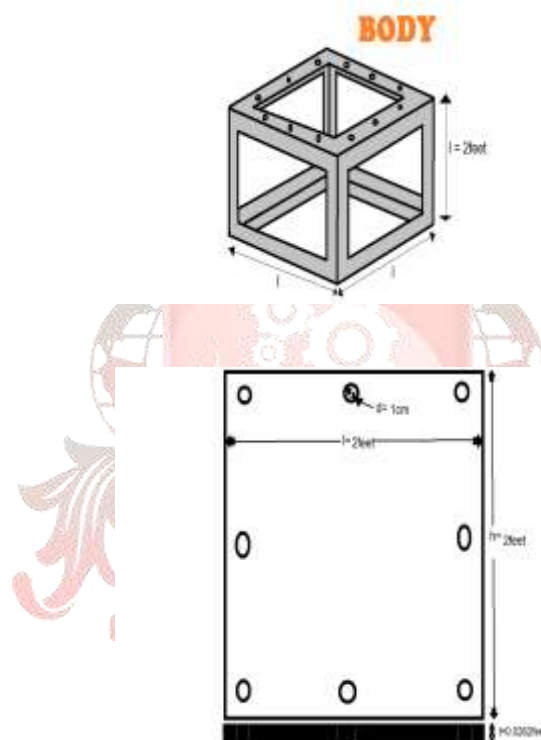

FIG. SHAFT BODY

BASIC COMPONENTS

The basic components of the dishwasher are:

1. Spray arm,
2. Spray supply pipe,
3. Booster pump,
4. Rotary union
6. Electric motor

Spray arm: The spray has ten spray nozzles through which the high-pressured water escape to the plates (dishes) the spray supply water with sufficient pressure which blast on the dishes causing stain removal action. The spray is rotated by a small electric motor connected to the pipe 1 by belt and pulley.

Spray Supply Pipe: this pipe is made of steel and it is directly connect the heat exchanger to the spray. It attached to the heat exchanger and the top. Bars by special bearings which allow free rotation on its stem is attached a speed reduction pulley connected by belt to the electric motor

Booster pump: booster pump increases low water pressure and flow. It provides the extra boost needed to bring your water pressure to the desired level

Rotary union: a rotary joints, also referred to as a rotary union or rotating union, is a rotary sealing device that's connect rotating equipment to fix piping for the transfer of steam, water, thermal oil, coolant, hydraulic oil, air, another media a rotary union is a union that allows for rotation of the united parts. It is thus device that provide a seal between a stationery supply passage and a rotating parts to permit the flow of fluid into and/or out of the rotating part

Electric Motor: The motor is a compressed type and has the function of rotating the pipe 1 thereby rotating the spray

MATERIAL SELECTION

To prepare any machine part, the type of material should be properly

Selected by considering design, safety and following points:

The selection of material for engineering application is given by the following

Factors:-

1. Suitability of the material for the required components.
2. Suitability of the material for the desired working conditions.
3. Availability of materials.
4. Cost of the materials.
5. In addition to the above mentioned factors the other mechanical & physical prosperities should be considered while selecting material for fabrication

FUTURE SCOPE

Scope for future work as suggested in above review is the project is carried out in order to get outside knowledge and involve in practical applications beyond in our day-to-day academic studies under in the module of "Advanced Topics in Mechanical Engineering". Design and fabrication is high efficient in minimum cost. This machine is very useful to the household women which is wash the dishes by the manually and its dish washing rate is more as compared to the manually washing the dishes. The cost of this machine is very less as compared to the market machine. It also can be used as a commercial machine such as wedding ceremony, hotels; etc drying of dishes after the cleaning process has been completed.

The motor is coupled with the rotating plate by spur gear mechanism. The shaft rotation depends upon the rotation of motor by spur gear mechanism. The high forced water is sprayed to the rotating plate by water pump. This is a simple type of semi-automation project This project is very useful in the

smart city project. This project can be further also modified as a mechatronics machine (this will make this machine fully automatic and more user friendly).

This machine is very useful to the household women which is wash the dishes by the manually and its dish washing rate is more as compared to the manually washing the dishes. The cost of this machine is very less as compared to the market machine. It can be used as a commercial machine such as marriage ceremony, hotels, schools etc. This can also be used in places where labourers are hard to find.

CONCLUSION

The proper guidance of project head and the sincere efforts of our group have lead to the successfully accomplishment of our concerned projects. **“DISH WASHER”** was interesting to work on and was also gained in this project work...

This knowledge of project will definitely be helpful in our future. So we must maintain that this final year project was an essential part of our engineering education enhancing our technical knowledge and practical skill.

Hand washing a common load of dishes, about twelve place settings, typically requires over eighty liters more water than a dishwasher. This work was designed to take less quantity of water compare to that wasted on manual hand washing of plates. In this project, the design of a special purpose dish washing machine was successfully carried out. Applying the overall wash ability index and performance standard index of dish washers from simulations carried out. The designed dishwashing machine, when fabricated will be very efficient and easy to operate. This work has established the fact that washing machines of different capacities can be manufactured locally in Nigeria without compromising standards. The work is rich with mechanical engineering design and so could be used for instructing undergraduate of mechanical, and mechatronic engineering.

REFERENCE

1. F. Odesola and O. A. Afolabi. “Design, Fabrication and Performance Evaluation of a Domestic Dish Washing Machine”. International Journal of Science and Technology Bahir Dar, Ethiopia, Vol. 1(1), pp. 164-173, 2012.
2. Sharma, H. Jain, C. O. Joseph and G. M. Lugo. “Influence of the manufacturing process on
3. Corrosion behaviour of soda-Li. silicate glassware”. Journal of the American Ceramics Society, 86: 1669, 2003.
4. N. S. Castro. “Energy and Water Consumption Testing a Conventional Dishwasher and an Adaptive Control Dishwasher”. NIST. Proceedings of the International Appliance Technology Conference, Columbus OH, May 1997.
5. D. Dhale, L. S. Ghodke, P. U. Hase, S. V. Jarag, and S. S. Shelar. “Design and Development of a Semi-Automatic Dishwasher”. International Journal of Engineering Research and General Science, vol. 3(3), pp. 108 – 112, 2015.

6. S. S. Hedao, C. C. Handa and V. D. Dhopte. "Design and Fabrication of Semi-Automatic Dish and Utensile Washing Machine". International Journal of Scientific Research and Development, vol. 4(05), pp. 1470 – 1473, 2016.
7. G. Brian. "Investigating the Insufficient Cleaning of Dirty Dishes in Confined Living Spaces and the Design of a Highly Marketable Dishwasher Solution". Bachelor of Science Research paper, University of Virginia, United States of America, 2010.
8. E. H. David, S. P. Danny, and H. H. Andreas. "How Energy Efficient are Modern Dishwashers". ACEEE Summer Study on Energy Efficiency in Buildings, Florida, 2008.
9. NSF International. "Residential Dishwashers". United States of America. NSF/ANSI 184, American National Standards Institute, ANSI, March 2003.
10. ANSI/AHAM. "American National Standards on Household Electric Dishwashers". United States of America. ANSI/AHAM-1-1992
11. T. Andy. "Can you connect a dishwasher to the hot water supply?". www.whitegoodshelp.co.uk/can-you-connect-a-dishwasher-to-the-hot-water-supply, Feb. 7, 2017 [Jan. 12, 2018].
12. NSF/ANSI. "NSF International Standard/ American National Standards for Food Equipment". United States of America. NSF/ANSI-2012.
13. R. S. Khurmi and J. K. Gupta. A Textbook of Machine Design. New Delhi: S. Chand and Company Ltd, 2010 reprint, pp. 611 – 645.
14. HOUGHTON. Table-furniture cleaning machine. m. 7,865. Patented May 14, 1850.
15. G. GOOHRAN, Dish washing 'machine. No. 355,139. Patented Dec. 28, 1886.
16. Pranali Khatake- "Design of Gears in Semiautomatic Dish Washing Machine". International Journal for Scientific Research & Development Vol. 4, Issue 09, 2016 pp. 836-839

