

Methodology of Measuring The Deviations of Geometric Shape of Hole

¹Barakaev Nusratilla Rajabovich, ²Juraev Jurabek Malikovich, ³Olimov Kamol Komiljonovich
Doctor of Technical Sciences, Professor¹, Assistant², Undergraduate Bukhara Engineering-
Technological Institute³

ABSTRACT

The article covers modernization of the roundness gauge of BE-20A model, because of which it became possible to measure the deviation from roundness and the deviation of the profile of the longitudinal section

Keywords: *roundness gauge, geometric shape, profile diagram, deviation from roundness, error, chart strip, non-roundness.*

INTRODUCTION

BE-20A roundness gauge was used in order to control the parameters of the geometric shape. In order to expand the functionality of the BE-20A model, its modernization was carried out, because of which it became possible to control the following parameters of the geometric shape of cylindrical surfaces: deviation from roundness and deviation of the longitudinal section profile.

The round gage model BE-20A is designed to measure the non-circularity or non-concentricity of cylindrical surfaces in a section perpendicular to their axis. The principle of operation of the roundness gauge is based on feeling the controlled surface of the part fixed on the centering table with the measuring tip of the rotating sensor. Registration of measurement results is carried out using a universal recorder on a circular chart in a polar coordinate system or on a chart strip in rectangular coordinates.

MAIN PART

Kinematic diagram of the modernized version of the roundness gauge is shown in Fig. 1. The device has a vertical layout and includes a frame 1, on which it is mounted on ball bearings 2, a centering table 3 and a rack 4 is rigidly fixed. A measuring head 5 is installed on the rails of the rack 4, which can be moved along the guides using rack and pinion 6. In the measuring head is mounted a drive for rotation of the sensor 7 with a measuring probe 8. The drive contains an electric motor 9, the rotation of which through the gear 10 and the elastic coupling is communicated to the precision spindle 11 and the sensor 7. The centering of the controlled part relative to the axis of rotation of the sensor is carried out by moving the centering table 3, in the horizontal plane in mutually perpendicular directions by means of two micro screws 12. Such kinematics has a serial device designed to measure non-circularity.

The modernization of the device consists in introduction of additional unit for precise axial displacements of the controlled part. The main elements of the assembly are a high-precision rod 13 moving in a guide sleeve 14, which is fast fixed in the central bore of the centering table 3. The gap in the contact between the rod-guide sleeves is sampled using a leaf spring 15 and a screw 16. A quotation table is installed on the upper end of the rod 17, with the help of which the axis of the tested part is set parallel to the axis of the rod. The drive for axial movements of the rod 13 is fast fixed in the frame 1 and contains a reversible electric motor 18 connected through a coupling with a lead screw 19, working in pairs, with a nut fixed from rotation with a sliding key (not shown in the diagram).

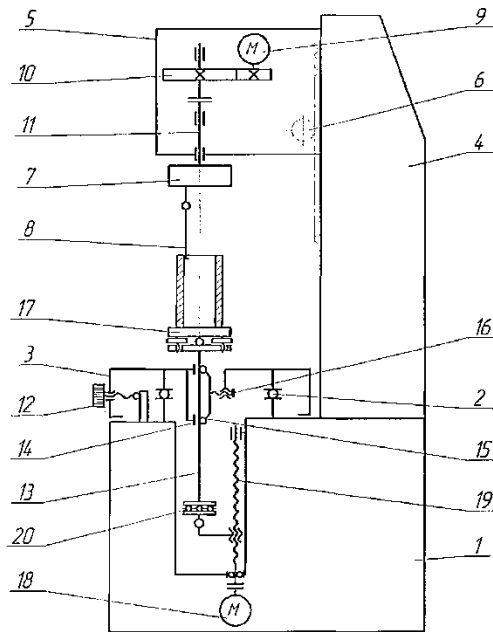

Fig. 1. Kinematic diagram of modernized BE-20A roundness gauge

When the lead screw 19 rotates, the nut, contacting through the ball bearing 20 with the lower end of the rod 13, imparts axial movements to the controlled part. The use of a ball bearing in the nut-rod contact eliminates parasitic radial loads on the rod when centering the part. This improves the measurement accuracy.

Speed of axial movements is chosen equal to the average speed of drawing the chart tape on the recorder and is 80 mm/min. The chart tape speed has six steps: 20, 40, 80, 200, 400, 800 mm/min. This allows recording the deviations of the shape in the axial section at different scales of magnification. The greatest length of the inspected cylindrical surface is 130 mm.

Thereby, the modernized BE-20A allows controlling practically all parameters of the geometric shape of cylindrical surfaces, i.e. deviation from roundness, deviation of the profile of the longitudinal section, as well as deviation from straightness in a given direction from one installation.

Checking the error of the device includes determining the error in the spindle rotation and the error in the axial movement of the rod. The spindle rotation error is determined by the roundness standard supplied with the device. The test procedure is described in the manual for the device. According to the passport data, the spindle rotation error should not exceed 0.15 microns.

In order to check the error of the axial movement of the rod, a glass plate of the PI type with a diameter of 100 mm, is used as a standard (GOST 292359). The deviation from the flatness of the working surface of the plate does not exceed 0.07 microns.

Verification diagram is shown in Fig. 2. The plate is installed on the adjustment table 17. The measuring probe 8 of the sensor 7 is brought perpendicularly to the working surface of the plate and the necessary preload is created according to the arrow of the centering indicator. After that, using a quotation table, the working surface of the plate is set parallel to the axis of movement of the rod. The alignment must be checked at successive switching of the steps of increase. In this case, during the time the probe passes the entire diametrical surface of the plate, the arrow of the indicator should not go beyond the upper small rectangle. After that, with the help of a recorder, a contour record is recorded on a chart tape, according to which the error of axial displacements is estimated.

Contour records are recorded at the maximum allowable magnification for two mutually perpendicular positions of the plate. The contour records recorded at a magnification of 10.000 (maximum magnification) determine the error of the axial displacement unit.

Checking results are shown in Fig. 3. The error of the sensor spindle rotation is less than 0.15 microns, and the error of the axial displacement unit at a length of at least 50 mm does not exceed 0.2 microns.

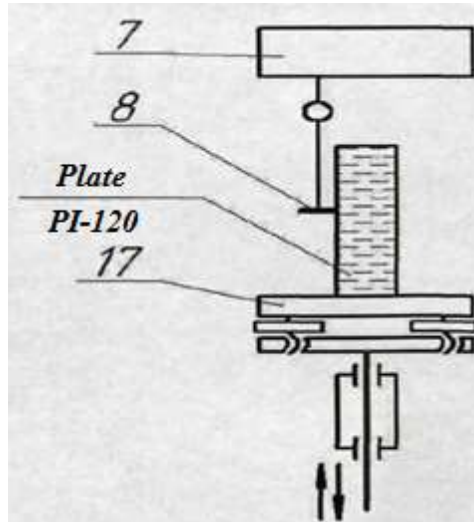

Fig. 2. Scheme of checking the error of axial displacement

In order to check the magnification steps of the electronic unit, the device is equipped with a special standard with two working belts and certified flats. The check is carried out by recording the corresponding belt of the standard on a round chart or on a chart tape. The deviations are calculated and compared with the actual value indicated on the standard. Checking results are shown in Fig. 4.

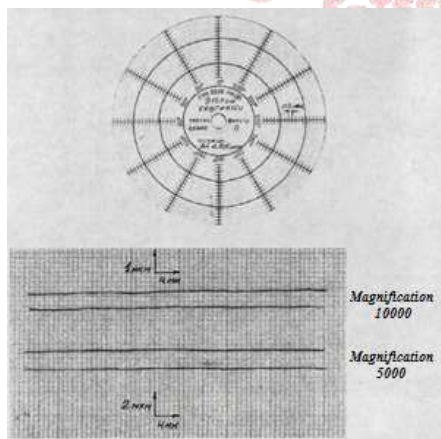

Fig.3. Checking results

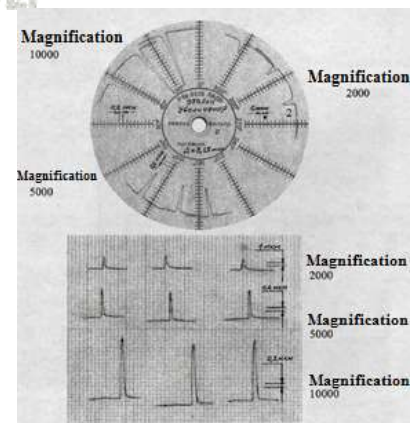

Fig.4. Checking results

In the experiments, the following parameters of the geometric shape of the cylindrical surfaces were controlled: the deviation from roundness and the deviation of the profile of the longitudinal section. Practically all measurements were carried out on a modernized BE-20A model. The methods for measuring the inner and outer cylindrical surfaces are identical.

The deviation from roundness in accordance with GOST 24642-81 is the largest distance ΔR_{max} from the points of the real profile to the adjacent circle. [1.2] In order to calculate the deviation, the device is equipped with a rigid transparent stencil, on which 16 concentric circles are applied with a step of 2 mm, which corresponds to a graduation step chart disk and tape.

The stencil is superimposed on the round chart and the maximum inscribed circle is selected when checking the hole. The greatest distance from the points of the real profile to these circles is found and, in accordance with the magnification scale, the roundness deviation ΔR_{max} is calculated. The nature of the error, that is ellipticity, cut, etc. is determined by the form of the round chart.

Deviation of the profile of the longitudinal section of a cylindrical surface is the greatest distance Δ_{np} from the points of the generatrices of the real surface, lying in the plane passing through its axis, to the corresponding side of the adjacent profile within the normalized area.

In order to determine the deviation Δ_{np} on the contour diagrams recorded on the chart strip, two parallel straight lines are drawn, in contact with the real profile of the axial longitudinal section and located outside the material of the part so that the greatest distance of the points of the real profile from the corresponding straight line in the aisles of the normalized area has a minimum value. Further, by measurements, the greatest distance from the points of the real profile to the corresponding adjacent straight line is found, and in accordance with the magnification scale, the deviation Δ_{np} is calculated. The nature of the deviation, that is cone-shaped, saddle-shaped, barrel-shaped, etc. is determined visually by the type of contour diagram.

For the entire range of parts, special mandrels were made for centering and fixing them on the instrument's adjustment table. Geometric deviations were measured in the following sequence.

1. Controlled part is fixed on the adjusting table with the help of a special mandrel 17 (Fig.1)
2. Tip of the probe 8 is brought to the inspected surface of the part, after which the measuring head 5 and the radial carriage of the sensor 7 are rigidly fixed. Further adjustment of the device is carried out by manually rotating the sensor.
3. Using the centering table, the controlled surface is centered relative to the spindle axis of the sensor rotation.
4. Using the quotation table, the vertical axis of the controlled surface is set parallel to the axis of the precision rod of the axial movement unit.
5. When performing point 4, the centering is corrected according to point 3. Operations on points 3 and 4 are repeated after each switching of the radial magnification.
6. Turns on the rotation of the sensor and when the blank is stationary, the round diagrams are recorded on the chart disk. Circular diagrams are recorded in two or three sections: at a distance of 2 mm from the ends (circular diagram A) and in the middle section along the length of the controlled surface (circular diagram B).
7. Rotation of the sensor is turned off, the axial movement of the controlled part is turned on, and the profile of the longitudinal section is alternately recorded in two mutually perpendicular axial planes and denoted by plane I and plane II. The profile is recorded on the chart strip.
8. Radial magnification is set depending on the stylus number and the amount of form deviation. All measurements were carried out with O or B filters, depending on the surface roughness.

CONCLUSION

In order to expand the functionality of BE-20A model, its modernization was carried out, because of which it became possible to measure the deviation from roundness and the deviation of profile of the longitudinal section

REFERENCES

1. Yakushev A.I. Interchangeability, standardization and technical measurement. Moscow: Mechanical Engineering, 1986
2. Balakshin V.S. and other. Interchangeability and technical measurements in mechanical engineering. Moscow: Mechanical Engineering, 1972
3. Mullabaev, B. B. (2018). ECONOMETRIC ANALYSIS OF VERTICAL INTEGRATION OF THE LIGHT INDUSTRY ENTERPRISES OF THE NAMANGAN REGION (ON THE EXAMPLE OF THE REPUBLIC OF UZBEKISTAN). *Scientific Review: Theory and Practice*, (8), 22, 36.
4. Mullabayev, B. B. (2018). Economic analysis of vertical integration integration of the Namangan region (on the prerogative of the Republic of Uzbekistan). *Science of theory: theory and practice"-8*.
5. Zaynutdinov, S. N., & Mullabayev, B. B. (2018). REGIONAL EFFECTIVENESS OF THE REGIONS. *Economics and Innovative Technologies*, 2018(1), 9.
6. Mullabaev, B. (2017). DEVELOPMENT OF LIGHT INDUSTRY BRANCHES IN UZBEKISTAN BASED ON VERTICAL INTEGRATION. *Бюллетень науки и практики*, (10), 178-184.

E-ISSN NO:2349-0721