**RENEWABLE ENERGY SOURCES - A KEY TO PROTECT ENVIRONMENT: A
REVIEW**

¹Anurag. D. Bhandarkar, ²Aniket. V. Deshmukh, ³Abhishek S. Gadre

Assistant Professor, Mechanical Engineering Department, Sipna COET, Amravati, MH India¹, Assistant
Professor, Mechanical Engineering Department, PRMIT&R Badnera, MH India², Assistant Professor,
Mechanical Engineering Department, Sipna COET, Amravati, MH India³

ABSTRACT

Reducing of fossil fuel sources and consequences of environmental problems arising from their consumption makes man to look for alternative energy sources including renewable energy sources. High consumption of fossil resources in the world is a warning for the necessity of exploiting the available abundant renewable resources such as solar energy, wind, geothermal and small hydro power plants. Therefore instead of growing reliance on declining underground resources, it must invest for the development of renewable energy utilization. Sun is the source of all energies. The primary forms of solar energy are heat and light. Sunlight and heat are transformed and absorbed by the environment in a multitude of ways. Some of these transformations result in renewable energy flows such as biomass and wind energy. Renewable energy technologies provide an excellent opportunity for mitigation of greenhouse gas emission and reducing global warming through substituting conventional energy sources. This paper aims to review on renewable energies such as solar energy, wind and bioenergy and their applications and the study also suggested some measures and policy recommendations which when considered would help achieve the goal of renewable energy thus to reduce emissions, mitigate climate change and provide a clean environment as well as clean energy for all and future generations.

Keywords: *Renewable energy sources, solar Energy, Wind Energy, Bio energy, Hydrogen as fuel.*

1. INTRODUCTION

The International Energy Agency estimates India will add between 600 GW to 1,200 GW of additional new power generation capacity before 2050. To fill the needs of the energy of this population, India have to look towards non-conventional energy resource which can fill a huge demand of energy generated by the population of India. India is fulfilling its 85% of energy demand from the conventional recourses such as coal, nuclear energy, natural gas and petroleum which generate many greenhouse gases. Green houses gases- carbon dioxide (CO₂), sulfur dioxide (SO₂), nitrous oxide (N₂O) etc. are produced in the energy generation process are not only harmful for people's health but it also deteriorates the environment vis-à-vis global warming and hole in the ozone layer. Thus it is the need of time that country should look towards the green & renewable methods for the generation of energy so that environment can be saved from those harmful effects. On the other hand the concentration of these gases in the Earth's atmosphere prevents heat leaving from the Earth and causes the increasing temperatures and extensive changes in Earth's climate, which is called the greenhouse effect. If the temperature continue rises in accordance with the current trend, it will be impossible to return to its former condition. Wind energy, solar energy, biomass & other renewable methods can be used for the generation of energy to fulfill the energy demands of the country. The best solution that can be offered is to stop the growing trend of these harmful gases and to utilize of other energy resources such as solar, wind, geothermal energy, thus this paper aims to review on these resource

2. ATMOSPHERE SCENARIO

Use of fossil fuel for the generation of electrical energy in power stations produces pollutions which is making nonliving atmosphere in the world, so it is mandatory to go for better alternatives for the energy requirement. Renewable energy resources provides pollution free atmosphere by reducing the effect of global warming and greenhouse gases. Climate change is one of the primary concerns for the humanity in the 21th century. The increasing concentration of greenhouse gases such as methane, carbon dioxide, nitrogen oxide,

ozone etc. in the atmosphere is acting to trap heat radiating from earth surfaces and is raising the earth’s surface temperature. A schematic representation of this global climate change is illustrated in below photograph.

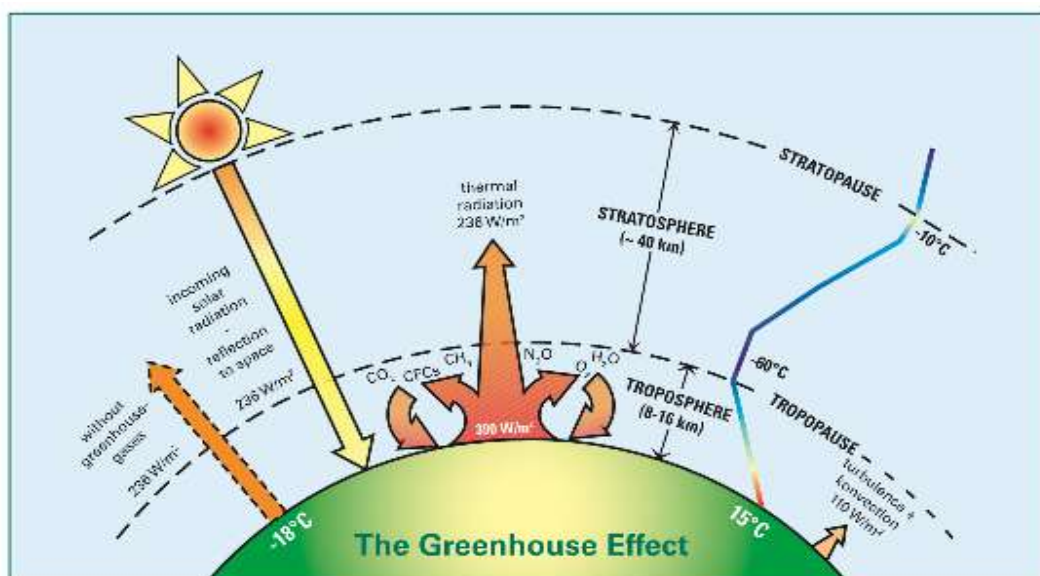

1) Fig-1 Illustration of greenhouse effect.

3. RENEWABLE ENERGY SOURCES

Renewable energy sources give us clean energy. Most of the energy generation at present is through non-renewable sources which may become extinct at any time, so our engineers must think about their responsibility to choose an alternative to avoid power crisis before facing critical situation. RES which is also called alternative energy sources can become the ultimate solution for the forthcoming power crises. At present RES contributes about 15% of the total energy generation of the world. RES includes solar, wind geothermal, hydropower, biomass and marine energies.[4] The RES are the primary, domestic and clean or the exhaust able energy resources. The following table 1 shows the renewable energy resources and their usage:

Table 1: Main energy renewable sources and their usage form

Renewable Energy Sources	Energy conversion and usage options
Solar	Solar dryers, Solar cookers
Direct Solar	Thermal Power generation, Water heaters
Wind	Power generation, Wind generators, Windmills, Water pumps
Modern biomass	Heat and power generation, Pyrolysis, Gasification, Digestion
Geothermal	Urban heating, Power generation, Hydrothermal, Hot dry rock
Hydropower	Power generation
Tidal	Barrage, Tidal stream
Wave	Numerous design

3.1 Solar Energy

The power from the sun intercepted by the earth is approximately 1.8×10^{11} MW, which are many thousands of times larger than the present consumption rate on the earth of all commercial energy sources. Thus if we convert this to other forms of energy, it may be one of the most promising of the non- conventional energy resources.

3.1.1 Solar Thermal Power

As far as renewable energy sources is concerned solar thermal energy is the most abundant one and is available in both direct as well as indirect forms. The sun is the earth's power station and the source of all energy on our planet. The ways capturing of the solar energy for many applications have become an important research area in recent days.[1]

Solar thermal energy is the technology used for harnessing solar energy for thermal energy (heat). A solar thermal collector captures the radiant energy from the Sun and converts it into heat. More recently, in a wide variety of thermal processes solar energy has been developed for power generation, water heating, mechanical crop drying, and water purification, among others. A major benefit of solar thermal power is that it has little adverse environmental impact, with none of the polluting emissions or safety concerns associated with conventional generation technologies. There is hardly any pollution in the form of exhaust fumes or noise during operation. Decommissioning a system is not problematic.

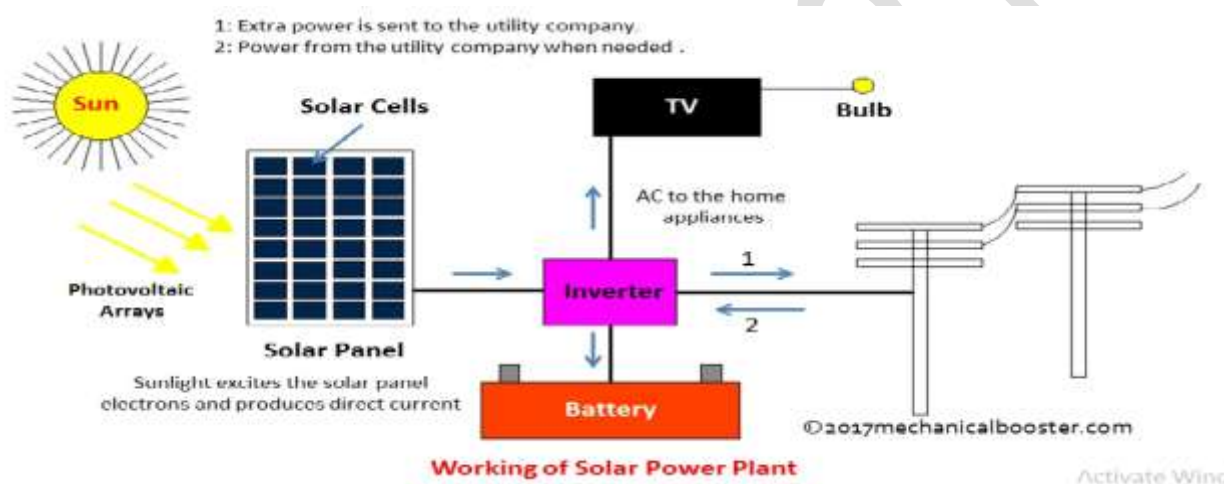

2) Fig-3 Schematic diagram of a solar thermal conversion system.

3.1.2 Applications of Solar Thermal energy in developing Countries

Solar collectors are a cheap and effective means of converting sunlight into thermal heat. There is vast scope to utilize available solar energy for thermal applications such as water heating, solar cooking, solar drying, crop drying, etc.

Water heating: The most common use for solar thermal technology is for domestic water heating. Hundreds of thousands of domestic hot water systems are in use throughout the world. The main components of a solar water heater are the solar collector, storage, and heat distribution.

Solar cooking: Over 80% of rural households use biofuels and animal dung for cooking. A vast majority of such homes burn firewood in traditional cook stoves (chulhas). This emits smoke and also has adverse environmental and health effects. Additionally, the process of collecting firewood is often an exhausting and time-consuming task. While small-scale solar cooking will benefit individual families in terms of health, large-scale solar cooking has the potential to save considerable fossil fuel. Solar cooking has several advantages since it requires very little maintenance, and saves cooking time and fuel cost.

Solar drying: Annually in India, about 35% of all agricultural produce worth roughly `500,000 million goes to waste during the post-harvest period. The loss is anywhere from 10% for durables (cereals and pulses) to about 40% for perishables (fruits and vegetables). Proper drying techniques for grains, cereals and pulses can ensure effective storage and reduce losses. Controlled drying is required for various crops and products, such as grain, coffee, tobacco, fruits vegetables and fish. Solar thermal technology can be used for this purpose.

Solar distillation: The most widely used application for solar water distillation has been for water purification. The advantage of solar over conventional systems in the purification of simple substances, such as brine or well waters, is that operation and maintenance are minimal because no moving parts are involved. Also, there is no consumption of fossil fuels in solar distillation, leading to zero greenhouse- gas emissions. Most importantly, these types of systems can be installed in remote sites to satisfy freshwater needs of small communities that do not have conventional electric service.

3.2 Wind Energy

Wind energy is available without any cost and it does not emit any greenhouse gases. This makes it a great source of energy production for any developing state. The field of wind energy has tremendous scope for innovation, translating to real world applications and tremendous economic opportunity. Clean, sustainable, renewable - and equally important, domestic sources of energy are essential to fulfill the potential of India in the coming years and it is certain that wind energy will play a major part in shaping India’s future. Of the renewable energy technologies applied to electricity generation, wind energy ranks second only to hydroelectric in terms of installed capacity and is experiencing rapid growth. Wind power has emerged as the biggest source of renewable energy in the world. Expansion of wind energy installed capacity is poised to play a key role in climate change mitigation.

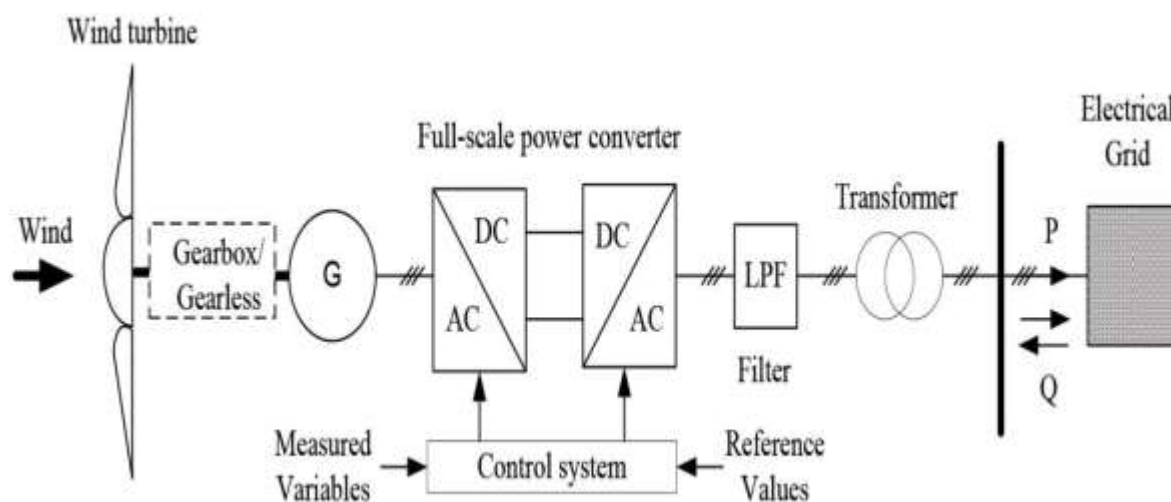

Fig-4 Power generation from wind energy.

Sources of Wind Energy in India

India has a vast coastal line which is a good resource of the fresh wind. Beside these there are other ways to generate the wind which need to get attention now. Highway windmill and Railway windmill is the option for production of energy in India. Offshore Wind Turbines is also a very effective method of generation of wind energy and energy which is generated by offshore wind is more as compared to on land

3.3 Bioenergy

There are various methods for producing bioenergy such as Biogas, Biodiesel, gasifier etc. The biogas has evaluated as one of the most energy- efficient and environmentally beneficial technology for bioenergy production. Biodiesel has the potential to reduce emissions from the transport industry, which is the largest producer of greenhouse gases. The use of biodiesel also reduces the particulate matter released into the

atmosphere as a result of burning fuels, providing potential benefits to human health. Gasifier is a device which converts solid fuel into gaseous fuel through thermo chemical conversion route. In the gasifier low grade fuel, i.e. biomass gets converted in high grade fuel known as charcoal and further into low calorific gas called producer gas.[3]

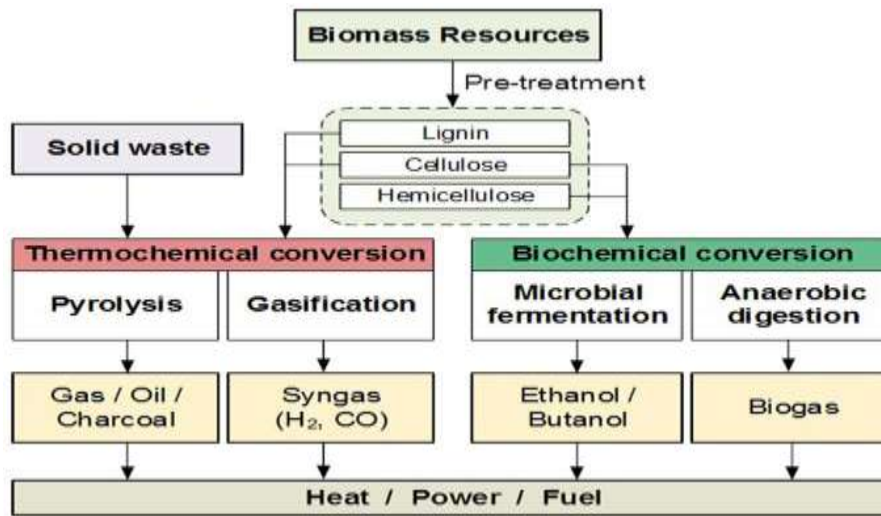

Fig-5 It shows the various process of deriving energy from biomass

4. CONCLUSION

Ongoing concerns about climate change have made renewable energy sources an important component of the world energy consumption portfolio. Renewable energy technologies could reduce CO₂ emissions by replacing fossil fuels in the power generation industry and the transportation sector so It is conclude that on the basis of discussion to overcome the effects of green house gases & global warming, Renewable Energy Sources is the only KEY for the fourth coming future of energy generation for the entire world. The paper explicitly points out the green house gas mitigation potential depending on the availability and use of renewable energy sources.

REFERENCES

1. Guduri Vijaya laxmi, Putla Paul Divakar, “Role of Renewable Energy Sources in environmental protection”, International Journal of Engineering Science Invention (IJESI) ISSN :2319-6734 PP 12-17
2. Stanislav Vezmar, Anton Spajic, “Positive and Negative Impact of Renewable Energy Sources” International Journals of Electric and Computer Engineering System Volume 5, Number 2, 2014.
3. N L Panwar, S. C. Kaushik, “Role of Renewable Energy Sources in Environmental Protection: A review, A Renewable and Sustainable Energy Reviews 15 (2011) 1513-1524.
4. Mohammad Shadabuddin, Sabiha Ahmed, Avinash Mohan Bhattacharya, “Environment Protection Through Renewable Energy Sources”, International Journals and Applied Research 2016; 2(9):97-99
Bilgen S, Kaygusuz K, Sari A. Renewable energy for a clean and sustainable future. Energy Sources, Part A: Recovery, Utilization, and Environmental Effects 2004;26(12):1119–29.
5. Fridleifsson IB. Geothermal energy for the benefit of the people. Renewable and Sustainable Energy Reviews 2001;5:299–312.
6. Demirbas A. Global renewable energy resources. Energy Sources, Part A: Recovery, Utilization, and Environmental Effects 2006;28(8):779–92.
7. Kralova I, Sjöblom J. Biofuels-renewable energy sources: a review. Journal of Dispersion Science and Technology 2010;31(3):409–25.
8. Dincer I. Environmental Issues. I. Energy Utilization. Energy Sources, Part A: Recovery, Utilization, and Environmental Effects 2001;23(1):69–81.
9. Sims REH. Bioenergy to mitigate for climate change and meet the needs of society, the economy and the environment. Mitigation and Adaptation Strategies for Global Change 2003;8:349–70.
10. **Youm I, Sarr J, Sall M, Kane MM. Renewable energy activities in Senegal: a review. Renewable and Sustainable Energy Reviews 2000;4(1):75–89.**