

AN EXAMINATION VIDEO SUVEILLANCE SYSTEM USING A MICROCONTROLLER - BASED MOBILE DETECTION MODULE

¹Oyedeji Ayo Isaac, ²Akinrogunde Oludare O, ³Akovojeun Ezekiel Gbenupo

Computer Engineering Department, Ogun State Institute of Technology (OGITECH) Igbesa, Ogun State, Nigeria¹, Electrical/Electronic Engineering Department Ogun State Institute of Technology (OGITECH) Igbesa, Ogun State, Nigeria², Computer Engineering Department, Aritspace Computer Institute, Lagos State, Nigeria³
ayooyee@gmail.com¹, akinrogunde2015@gmail.com², gbenupoezekiel@gmail.com³

ABSTRACT

Examination malpractice has left a deleterious effect in the educational system to the extent that the worth and competence of students cannot be measured through academic certificates only. This work is conducted with the objective to “develop and implement an “AN EXAMINATION VIDEO SUVEILLANCE SYSTEM USING A MICROCONTROLLER BASED MOBILE DETECTION MODULE” which can be used to detect the presence of signals in the range of 0.9GHz to 3GHz within a radius of one and a half metres and also produce a notification when the specified frequency range are detected. An activated mobile phone from a range of one and a half meters, captures the current view of the student (scene) as soon as the GPS data is received in order to prevent the use of the same in an examination halls and restricted places such as prisons, meeting places.

The mobile phone detector detects any incoming/outgoing calls/SMS and then sends a wireless serial data using the Bluetooth module to the Invigilators android mobile application. The data sent, contains the GPS latitude and longitude coordinates of the detector device location where the mobile phone signal was detected. The android mobile application which was developed to receive the live feed video stream of the Wi-Fi Camera captures the current view of the student as soon as the GPS data is received. The received GPS data was then used to calculate the distance of the detector device from the invigilators mobile phone. The distance calculated was made possible using the Google Map API V2 which has the LatLng objects that determines the distances between two known latitudes and longitudes GPS coordinate data. The cell phone detector device also has a buzzer alarm which sounds an alarm to notify the invigilator when a cell phone is in use

1.0 INTRODUCTION

Examination malpractices are detriment to Nigerian educational system reducing the standard and the value of the country's academic performance and certificates. Most foreigners say that the academic certificates being issued to graduates in Nigeria are no more valuable than the pieces of paper on which they are printed [4]. Examination malpractice is an illegal behaviour by a candidate before, during or after the examination so that such can attain success easily and cheaply. Hence, the worth and standard of the examination is breached. Examination malpractice is like a cankerworm that destroys the academic credibility and honour of a nation. Most exam malpractice carried out by students, involves the use of mobile cell phones which are normally used to make an incoming/outgoing call, send/receive SMS messages while there in the exam hall.

This work tends to prevent exam malpractice by introducing the use of a mobile cell phone signal detectors and camera capture feature. The mobile phone detector detects any incoming/outgoing calls/SMS and then sends a wireless serial data using the Bluetooth module to the invigilator's android mobile application. The data sent, contains the GPS latitude and longitude coordinates of the detector device location where the mobile phone signal was detected. The android mobile application which was developed to receive the live feed video stream of the Wi-Fi Camera captures the current view of the student as soon as the GPS data is received. The received GPS data was then used to calculate the distance of the detector device from the invigilators mobile phone. The

distance calculated was made possible using the Google Map API V2 which has the LatLng objects that determines the distances between two known latitudes and longitudes GPS coordinate data. The cell phone detector device also has a buzzer alarm which sounds an alarm to notify the invigilator when a cell phone is in use.

The Polytechnic has a “NO mobile phone in examination halls” regulation. Students undergo frisking as they enter the examination venues by invigilators. Frisking is gender sensitive and people feel that their privacy is infringed. It is beyond one’s imagination of what can happen when there is no Female staff to frisk the female students which is mostly the case in the School of Engineering Technology (SET). This is not saying that only female students are prone to carry their mobile phones into the examination halls but it opens doors for gross irregularities as the contents of these gadgets can be easily shared via messages and Bluetooth.

The versatility of mobile phones cannot be underestimated. They are very portable and compact and can perform an array of functions ranging from a simple call, SMS, data services, a simple digital organizer to those of a low-end personal computer. Most mobile phones have a basic set of comparable features and capabilities.

2.0 LITERATURES

2.1 Introduction

Exploring the features of most cell phones show that they have a microprocessor, a read only memory (ROM) that provides a storage for the operating system, a Random Access Memory (RAM) that temporarily provides storage for data when the cell phone is powered, a radio module, a digital signal processor, a microphone, a speaker, a variety of hardware keys and interface and a liquid crystal display (LCD) [1].

A focus to detect mobile phones has therefore to focus on these features to determine the potential vulnerability as entry points. Tests were carried at Pacific Northwest National Laboratories (USA) to determine the potential vulnerability of the microphone, speaker and RF system as entry points for detection.

2.2. The RF System: The first part on determining the RF system as potential detection point was carried out by looking for the internal oscillators necessary to operate the microprocessor and RF synthesizer. The results were not satisfactory and it was established that the cell phones had been designed to meet the electromagnetic interference specifications.

The second part of the experiment was carried out to detect the cell phone by detecting the RF transmitted. This was done by the use of an RF signal strength meter, an amplifier, a mixer and a filter. They found out that since the mobile phone keeps a continuous communication with the tower, this technique was successful [2]

2.3. Combined Audio and RF Signals: The combined audio and RF signal tests were done by carrying out a magnetic coupling test as shown in figure 2.1 below.



Fig 2.1: Magnetic coupling test set-up

In this test a frequency synthesizer was used to drive one coil at 28MHz and a spectrum analyser used to monitor the output of the second coil. The cell phone's presence or position relative to either coil made no change in the observed signal from the second coil.

A modification was made that incorporated an audio speaker to make the cell phone's microphone or speakers react to the audio signal with an RF spectrum analyser configured to demodulate AM signals.



Fig 2.2: Combined Audio and RF set-up

A block diagram of the setup is in fig 2.3 below. The RF transmitter and receiver was to be used to sense cell phone when reacting to the audio signal.

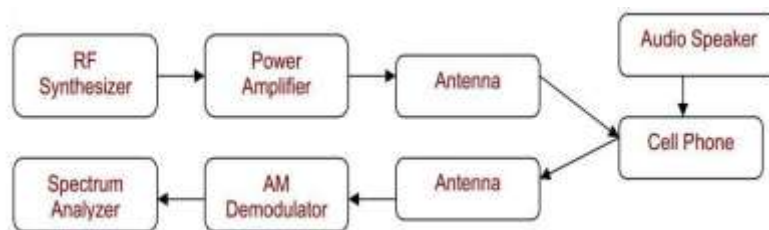

Fig 2.3: Combined Audio and RF block diagram

The results obtained from the test were encouraging but the cell phone was found not to respond when shielded.

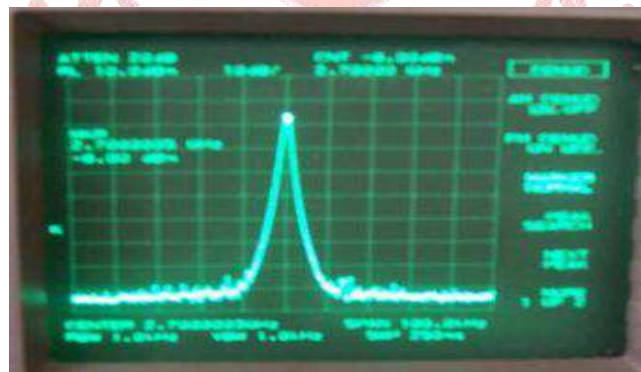

Fig 2.4: Results

2.2 Commercial Cell Phone Detectors

Cell phone detectors have been in the market for many years. They have been in use in prisons and correctional institutions to ensure that inmates do not smuggle or use cell phones in the facility, in government institutions and security teams in the USA for long..

2.2.1 Wolfhound™ Pro Cellphone Detector: This cell phone detector is manufactured by Berkeley Varitronics Systems in the Unites States of America (USA) [2]. According to the advertisement note on their brochure, this cell phone detector can detect cell phone operating on 3G and 4G. It identifies each cellphone by RF frequency allowing for detection and identification of multiple cellphones. Its antenna uses a multiband

Directional Finding (DF) antenna system with an ability to detect up to 150 feet (about 50 metres) for indoor applications and one mile (line-of-sight) for outdoor application. It is listed as the most sensitive cell phone detector in the market. It comes with user band frequency selection depending on the country to be used.



Fig 2.5: Setting up screen

The detector can detect phones in standby mode. The registration varies with base stations with phones registering once every few minutes up to 20 minutes. This time varies greatly based upon carriers, distance from base station and individual cell phone manufacturer's standards.



Fig 2.6: Wolfhound pro cell phone detector

It had a dynamic range of 60dB and a bandwidth resolution of 2MHz. This detector has a threshold setting and comes with optional PC software which receives data from the detector via a mini USB port allowing real time monitoring, generation and printing of reports, and saves logs into an SQL database.

2.3 Detection Techniques

2.3.1 RF Spectrum Approach: Every mobile phone uses the frequency spectrum for communication. Manufacturers use different frequencies in their mobile phones for communication depending on the federal laws of the country and radiation regulations. A study carried out by Pacific Northwest National Laboratory for the United States Department of Energy on cell phone detection using this technique showed that different phones propagated using different frequency ranges. [4]

- An LG cellular phone had distinctive signals from 260MHz to 300MHz.
- A Motorola cellular phone had distinct signals in the range of 240MHz and 400MHz.
- A Samsung cell phone had distinctive signals between 340MHz and 385MHz.
- Nokia cell phone had distinct signal at 245MHz.

In this detection approach, a passive circuit listens for any emissions from a cellular phone when it is either waiting for a call or transmitting and does not require an external signal to detect the phone. This is advantageous especially in areas where power emissions from electromagnetic sources are highly prohibited.

The circuit implementation of this approach differs in so many ways. One of the approaches is in fig 2.9 as a block diagram.[3]

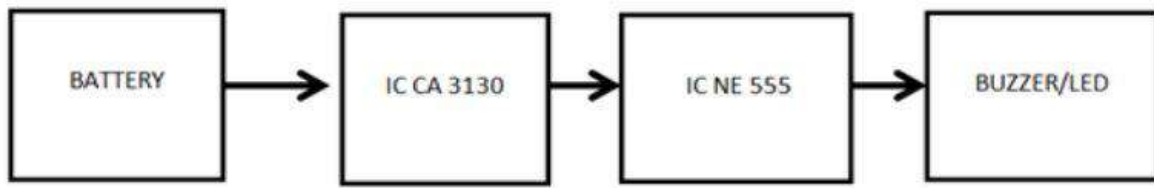

Fig 2.9: Block diagram

For versatility, an LCD can be interfaced to notify the person monitoring of a cell phone detected. This ensures that even when the power level is low, like in the case of standby phone, to drive the buzzer, a notification like “MOBILE PHONE DETECTED” will be of use as an alarm.



Fig 2.10: LCD Integration

Fig 2.11 shows a typical implementation circuit for the detector using the approach of the block diagram of figure 2.9.

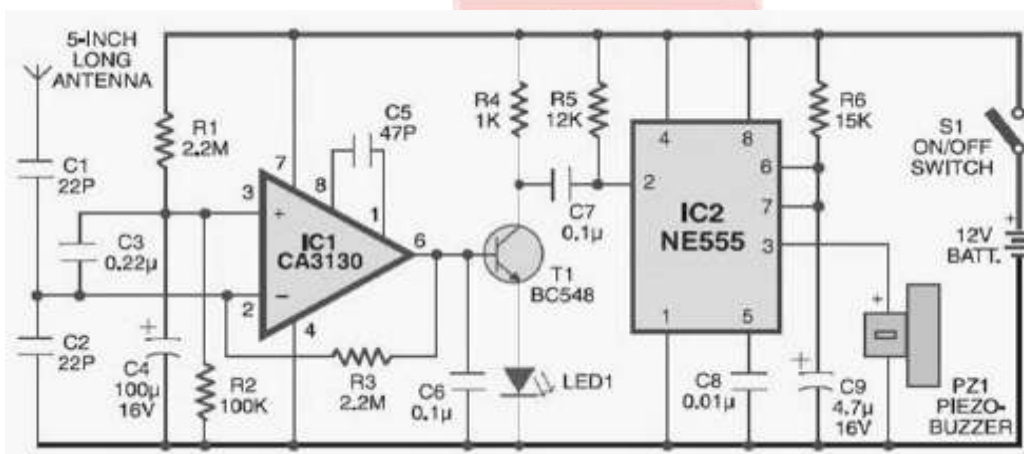

Fig 2.11: Cell phone detector typical circuit

The second proposed approach using this detection technique is the use a frequency down converter with a band pass filter [4].

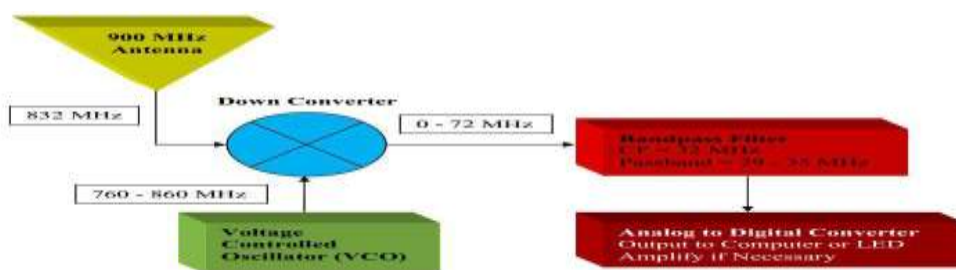

Fig 2.12: Cell phone detector with frequency down converter

The RF spectrum measurement approach had shortcomings. The iPhone propagation range could not be detected. Another highlighted shortcoming is that even in the absence of a cell phone, signals could still be detected. The proposed solution to this problem was to design a circuit that masked the signals detected in the absence of a cell phone. It was proposed that a “passive infrared detector be included in the system to detect the

presence of a person at the entrance to a limited area. Its function will be to cause the Cell Phone Detector to transition from measurement of the background signals into the cell phone detector mode”.

2.3.2 Frequency Jamming :Mobile phones work by transmitting signals between the mobile phone and the base station or tower. Therefore, one of the methods to detect the mobile phone is to have another device transmitting at the same frequency as the mobile phone but at higher power level. As the phone signal is interfered by the device, service on the phone is blocked. Since the phone may be moving around and therefore its signal handed over from one base station in a cell to another, the jamming device performs well when placed in between two the two cells to ensure total denial of service [5].

The person interested in detecting the phone is usually not concerned with the exact location but only the fact that there is no communication via the phone. Parties can therefore enter the locality with the devices but cannot use them for calls, emails, Bluetooth or SMS provided the jamming device propagates at the frequency these services use.

The devices that jam frequencies consist of the following parts in the circuitry:

- **Voltage controlled oscillator (VCO):** The VCO generate the frequency at which the cell phone transmits and therefore interfere with the communication.
- **Tuning circuit:** This circuit controls the frequency at which the jammer broadcasts its signal by sending a particular voltage to the oscillator.
- **Noise generator:** It produces random electronic output in a specified frequency range to jam the cell-phone network signal. It can be part of the tuning circuit.
- **RF amplification:** This is the stage where the gain is provided. It boosts the power of the radio frequency output to higher levels that are enough to jam a signal from the mobile phone.

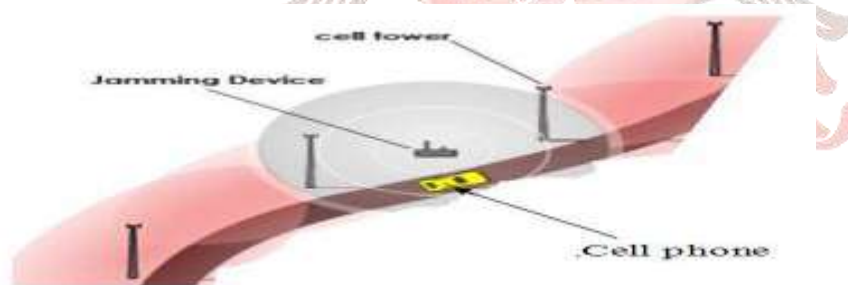

Fig 2.13: Cell phone jammer in a cell

This type of detection has been in use in movie theatres, correctional institutions and in the military to name but a few. Some of the jammers can be tuned in to different frequencies and therefore can be used to block specific devices only. They can be handheld or installed in buildings or any other places where they need to block the mobile phones.

The disadvantage of this technique is that cell phones in the jammed locality can still be used for other services such as data mining which pose a very big problem in companies. In the case of examination halls, the phone smuggled can be used in examination irregularities despite having a jammer in the hall. This method therefore proves to be ineffective in cases where cell phone usage is prohibited.

3.1 System Block Diagram

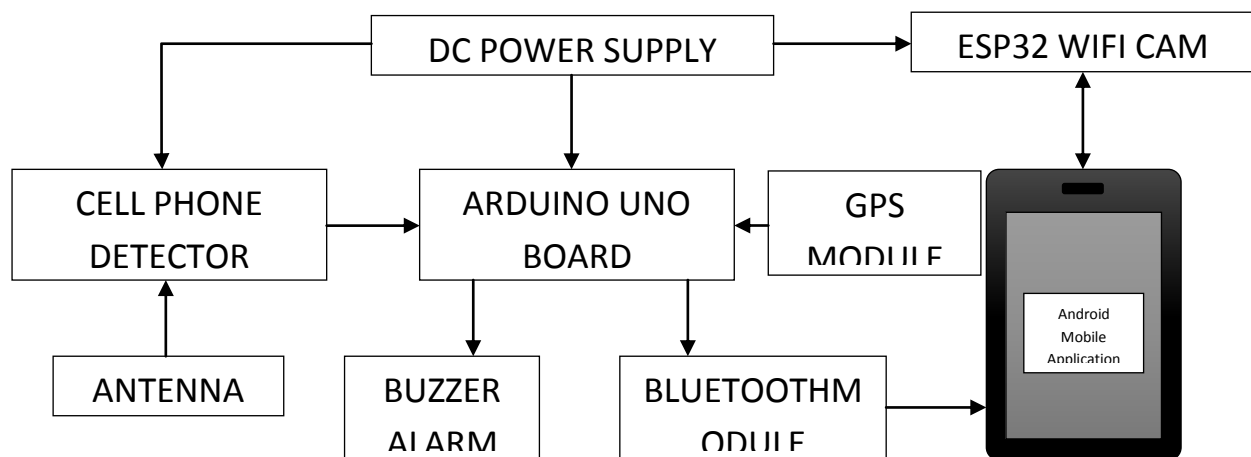

Figure 3.1 System block diagram

3.1.1 DC Power Supply

The entire system was powered using a 12.6V DC supply derived from three rechargeable Lithium Polymer Batteries connected in series with each battery having a voltage rating of 4.2V and battery capacity of about 1800mAh.

3.1.2 Mobile Phone Detector Block Diagram

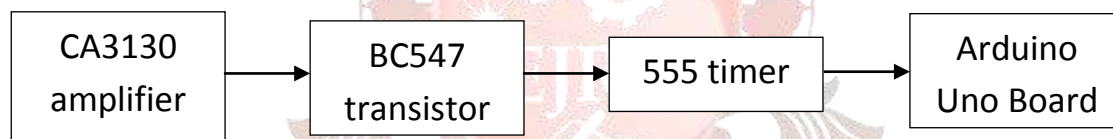

Figure 3.2: Mobile phone detector block diagram

The cell phone detector circuit was built around the CA3130 operational amplifier. The mobile signal which was picked up using the telescopic antenna was coupled via a 22pF capacitor to the operational input. The operational amplifier amplifies the received signal and then outputs the amplified signal to the BC547 NPN transistor, which in turn, turns ON the BC547 NPN transistor that then triggers the timer 555 chip. The timer 555 output signal was then sent to the ATMEGA328P Arduino Uno board chip.

3.1.3 Arduino Uno Board

The Arduino Uno Board was built around the ATMEGA328P microcontroller chip. The microcontroller chip which is programmable chip was programmed to control the entire operation on the detector circuit. The basic operation of the Arduino Uno Board was to detect the timer 555 input's signal. then obtain the GPS coordinates from the GPS module, turn ON the buzzer alarm and then send the GPS data to the mobile phone serially using the Bluetooth module.

3.1.4 Bluetooth Module: The Bluetooth module used was the HC-05 which was used to connect to the mobile phone so as to send the received GPS data information to the mobile phone from the detector device serially with a baud rate of 9600.

3.1.5 Buzzer Alarm: The buzzer alarm as the name implies, was used to output an alarm each time a mobile phone signal was detected.

3.1.6 ESP32 Wi-Fi CAM: The ESP32 Wi-Fi Cam is an IP camera device that was configured with a unique SSID name and password which enables it connect to the mobile phone hotspot and then its video feed was received when its IP address was visited on a web browser page connected on the same local network with the camera.

3.1.7 GPS Module: The GPS module used was the GY-NEO6 MV2 GPS module whose function was to connect to the space satellite stations each time it's turned ON. It was used to receive the latitude and longitude data of any position on the earth's surface.

3.2 System Flow Chart

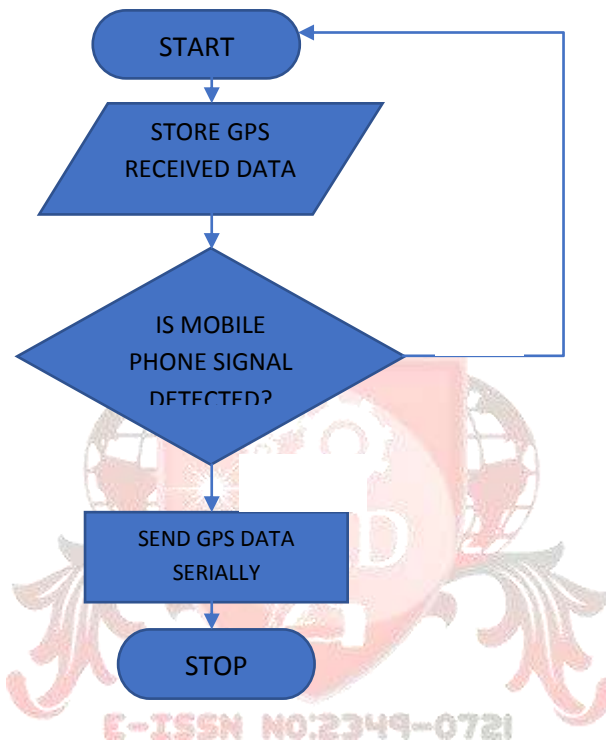

3.3 Design Procedures

In the course of my research, I realized that there are several approaches to designing mobile phone detection system with live feed video. The constant thing with either approach is the use of a microcontroller chip, and the difference was with the use of a GPS module Bluetooth Module and Wi-Fi Camera. The project could be done automatically though it was manual in the following steps;

STEP ONE: sourcing of components and the necessary tools that will be needed to ensure time management during the design.

STEP TWO: testing of the various components using a meter to ensure proper functionality and maintain specification.

STEP THREE: mounting of components on the project board, checking of correction to avoid short circuiting.

STEP FOUR: pre-testing of the assembled components on a project board, reading at various stages to ensure functionality and some adjustments were made.

STEP FIVE: transfer of the components to a vero board and then soldering of joints as required. Proper care was taken at this stage.

STEP SIX: testing of the soldered project and finally casing in a speaker box and retesting to make sure no part is affected.

STEM SEVEN: coding of the software part using java programming language

3.4 Tools Used For Testing and Construction.

The testing, construction and implementation of the project involved the use of some engineering tools and equipment in the workshop as listed below;

Digital Multimeter: multimeters are basically devices for measuring voltage, resistance of resistors, continuity and current. It has two types; Analog and Digital multimeters. The process of implementing the design on a project board required the measurement of resistance at each stage, voltage drop or gain, continuity, current and in some cases frequency measurement. Thus measurements were done using a digital multimeters.

Soldering Iron: this is an electrical heating device used for joining components and devices on a board using soldering lead. They are rated in watts and are commonly seen in the market is the 60watts type. During this project design, a 25watts soldering iron was used to avoid overheating of components.

Pairs of Cutters: this is a device for cutting cables and reducing the length of component leads before and after soldering.

Long Nose Pliers: this is a type of pliers with long teeth, used for holding, picking or twisting cables and components before and after soldering.

Project and Veroboard: the project boards are used for initial and temporary implementation of the project to test the functionality of the design while the Vero boards are used for final construction of the project.

Lead Sucker: a simple device that applies the principles of a vacuum pump, used to suck or remove excess lead from the board ensures neatness of the work.

Screwdriver: a device for driving in and out of screws.

Arduino Ide: an Integrated Development Environment for writing and uploading computer code to the Arduino physical board

Android Studio: an Integrated Development Environment (IDE) for the coding and testing of the android application.

4.1 COMPONENTS ASSEMBLING

The design and construction of the Mobile Phone Detection System was carried out using available materials. The construction of the circuit was carried out on a perforated Vero board after series of testing were made using a breadboard in the laboratory. In this chapter, the design methods or stages used in the search work are discussed and some important calculations carried out to arrive at some values used are highlighted.

- Components were arranged in such a manner to achieve compactness
- Transistor and resistor were carefully tested before mounting to avoid damaging them and ensure proper functionality.
- Proper polarity of components was maintained while mounting.
- Long interconnections were avoided to maximize stray capacitances.
- Proper soldering at various joints were done to avoid cracked joints, excessive heat that could damage components was avoided.
- The leads of components were cleaned with a piece of emory papers and bent at the correct distance from the components body and inserted properly in its place in the boards.
- All polarized capacitors were carefully inserted in place and soldered to avoid damage to the component and the entire circuit.

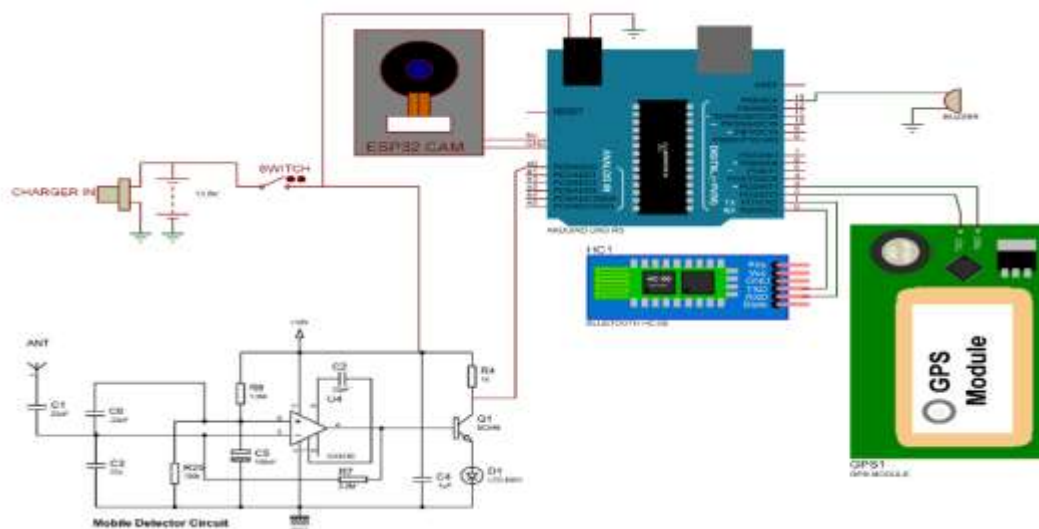

Figure 4.1: System Circuit Diagram

4.2 Android Application Development

The Android mobile application was development using the android studio environment using java programming language. Below diagram shows the user interface design.

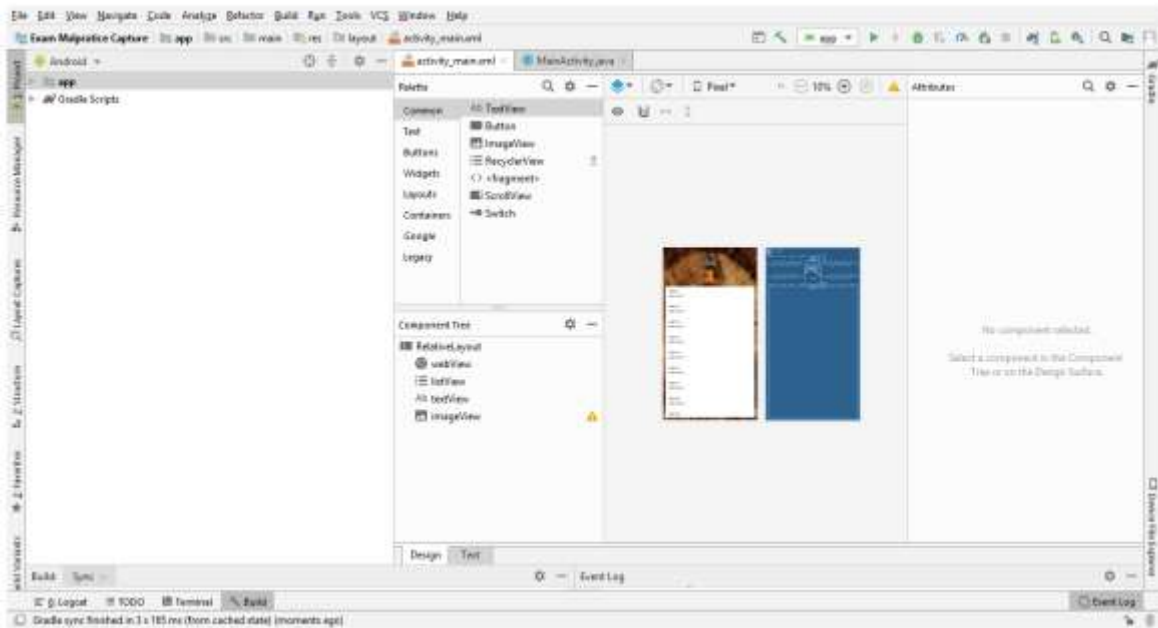

Figure 4.2: Android application development environment



Fig. 4.3 Internal Assembly of the Components of the System



Fig. 4.4 Front View Completed System



Fig. 4.5 System Side View Charging Port

4.3 Result

The main objective of this project was achieved following keenly the methodology and construction procedures. The android mobile application was to provide an interface where the live stream video can be view as well as to enable the instant image capture and storing. The mobile application was also used to calculate the distance between the cell phone detector device and the invigilator's position. So as to enable the invigilator locate the student easily



Fig. 4.6 Result showing live capture of scene

4.4 Testing

This is where the designer check to see if the finished work on a Vero board or printed board meets with the design specifications. After carrying out all the proper design and analysis and possibly computer simulation, the project was fine and also met the design specifications. Several tests were carried out in the laboratory to determine the voltage calibration accuracy. Two stages of tests includes;

1. Pre implementation testing, all the components which includes (Resistor, Capacitor, Transistor, Transformer, etc.) Used in the realization of the design were tested using a multimeters, set to the right configuration to ensure that they are working fine, also continuity test was done to test for open circuit and to check whether or not wired properly.
2. Post implementation testing, the voltage at each stage of the project was tested to ensure it is 12V and 5V D.C, this was done using a multimeters. The diodes were also tested using the multimeters, also the DC resistance of the relay coils was tested.

CONCLUSION

The results as obtained from fig 4.2 through fig 4.4 show that the cell phone detector worked sufficiently. The detector could detect the signal in the frequency range of 0.9GHz to 3.0 GHz thus a cell phone that is in use.

This phone usage was indicated by the blinking of the LED. When a cell phone is on standby mode, it keeps a radio silence therefore cannot be detected using this cell phone detector. It can be concluded that the project was successful.

This detector can therefore be used to track the usage of a cell phone in an examination room where a buzzer usage will be too loud and disturb the examiners.

RECOMMENDATIONS AND FURTHER WORK

The following are recommended to improve the functionality of this cell phone detector: -

- (i). Increase the range of the detector.
- (ii). Incorporate a buzzer to sound an alarm when a cell phone in use is detected.
- (iii) Use of microcontroller to improve the detector.
- (iv). Make the LED go off until a cell phone is in use.
- (v). Improve the detector to be able to detect even cell phones on standby mode

REFERENCES

1. RM Pratt et al., "Cell Phone Detection Techniques," TN, Prepared for the US Department of Energy October 2007.
2. Berkeley Varitronics Systems, Inc. (2016, March) Wolfhound-PRO Cell Phone Detector. [Online]. <https://www.bvsystems.com/products/>
3. Deshpande Tamvi and Jadhav Nakul, "Active Cell phone detection and Display using Atmega-8 Microcontroller," IMPACT: International Journal of Research in Engineering & Technology (IMPACT: IJRET), vol. 3, no. 8, pp. 21-24, August 2015.
4. Nicholas W. Scott, "Study of Cellular Phone Detection Techniques," University of Nebraska, Lincoln, MSc Thesis 2011.
5. HowStuffWorks. (2005, January) How Cell Phone Jammers Work. [Online]. <http://www.electronics.howstuffworks.com/cell-phone-jammer.htm>
6. Garry Breed, "Fundamentals of Passive Component Behaviour at High Frequencies," Summit Technical Media, High Frequency Design: Component Behaviour 2006
7. Pieter L.D. Abriel, Design of RF and Microwave Amplifiers and Oscillators, 2nd ed. MA, Norwood: Artech House, 2009.
8. Iulian Rosu, "Bias Circuits for RF Devices," YO3DAC/VA31UL,.