

**INNOVATIVE APPROACH TOWARDS MEASUREMENT AND ANALYSIS OF  
PRIMARY HUMAN BODY PARAMETERS BY DESIGNING & IMPLEMENTING  
V Health Plus**

<sup>1</sup>Ms. Tejal Anil Dhaimbekar, <sup>2</sup>Mr. Amit Maruti Ghanvat, <sup>3</sup>Ms. Harshali Prabhakar Mali, <sup>4</sup>Mr. Vipresh  
Digambar Todankar, <sup>5</sup>Prof. Nikhil Nathuram Kasar, <sup>6</sup>Mr. Aniket Pratap Bendre

B.E. Department of Electrical Engg. Vishwaniketan's Institute of Management Entrepreneurship and  
Engineering Technology, khalapur Raigad, India<sup>1,2,3,4,5,6</sup>

tejaladhaimbekar@gmail.com<sup>1</sup>, amitghanvat9@gmail.com<sup>2</sup>, harshalimali16@gmail.com<sup>3</sup>, vipresht@gmail.com<sup>4</sup>,  
nnkasar@vishwaniketan.edu.in<sup>5</sup>, aniketbendre6169@gmail.com<sup>6</sup>

**ABSTRACT**

Nowadays, life full of hustle and work maintaining human body fitness is very crucial. The first step towards being conscious about fitness tips to get accurate health parameters in a convenient and economic manner. This paper explains the innovative approach towards the measurement of body mass index that is the ratio of body weight and height. This proposed body monitoring system has compiled a measurement of BMI, Oxygen saturation level, Heart rate and Body temperature. The arithmetic operations are performed by Arduino Uno Central microcontroller which is derived from programming in C language. This prototype requires a power supply. So, the DC-DC Converter is designed as the battery backup to the project. It gives output of 5v-58v DC by implementing a boost converter in it and can vary by using potentiometer. The hardware implementation of this project is completed with the help of 3D modeling software and actual fabrication of the project. A survey on various people is conducted to prove the accuracy and Precision of V-Health Plus. The results indicate that V-health plus is a precisely accurate primary body monitoring system.

**Keywords—** *Arduino UNO, Body temperature, Heart Rate, Oxygen Saturation level, Ultrasonic Sensor, Load Cell, LCD Display, Body Mass Index, Weight Scale, V Health Plus.*

**INTRODUCTION**

A person's BMI is outside of the healthy range, their health risks may increase significantly. Carrying too much weight can lead to a variety of health conditions, such as type 2 diabetes, high blood pressure, and cardiovascular problems. A weigh that is too low can increase the risk of malnutrition, osteoporosis, and anemia. The doctor will make suitable recommendations.

V HEALTH + is an only approximation for determining the health problems, but it can be used as a diagnostic tool by further. It measures BMI (Body Mass Index), Heart Rate, Oxygen saturation level (SPO<sub>2</sub>), Temperature of the body simultaneously by implementing Arduino uno (ATmega328P). Through this measurement, physicians can recommend different health risks related to weight to height ratio. A nutritionist can decide the diet of a person, and other screening of a person's health.

The weight is calculated by a load cell; Height is calculated by using the ultrasonic sensor which both transmits and receives ultrasound waves. The signal which is received from the load cell and ultrasonic sensor are then further fed to Arduino uno (ATmega328P), where calculations are performed. The formula:  $\text{weight(kg)} / \text{height(m)}^2$  has been kept in its original form, and a universal scale classify individuals in underweight ( $\leq 18.5$ ), normal-weight ( $18.5 < 25$ ) and overweight ( $\geq 25$ ), each class includes several subclasses [1], [2].

Pulse Oximetry sensor (MLX90614) is a personal monitoring device that measures Heart rate and Oxygen saturation level (SPO<sub>2</sub>) at the same time, that signal sent to Arduino uno (ATmega328P). Heart rate simply indicates the soundness of our heart. It helps assess the condition of the cardiovascular system [3]. A heart rate monitor is a simple device that takes a sample of heartbeats and calculates the heart beats per minute and this information can easily track the current heart condition [6].

The infrared temperature sensor is a measurement device that measures temperature by sensing a corresponding physical quantity. A temperature sensor has been used to measure body temperature without contacting the body. The microcontroller of the Arduino UNO board is programmed to count the pulse rate and to measure the body temperature[5].

## II. PROBLEM STATEMENT

To measure primary health parameters of the human body, namely BMI, Oxygen saturation level, Heart rate, Body temperature, and diagnose the health condition which is recompiled in one compact microcontroller-based electronic system, in an economic approach to meet industrial standards of a body monitoring system. In Covid-19 situations primary testing is mandatory means contactless temperature monitoring and oxygen saturation level. At present time also electricity is not available in every rural area. There are many causes of power failures in the electric network and our project required power supply so we designed a battery backup system.

### DEVELOPMENT OF BLOCK DIAGRAM

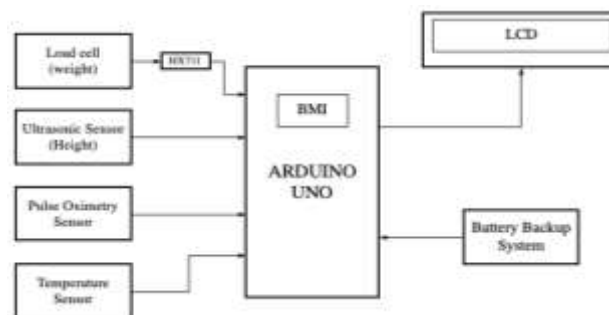

Fig. .1 Block Diagram

The weight of the human body is calculated by using the load cell. The load cell acts as a transducer which converts physical input applied force into an electrical signal which further sends it to the amplifier (HX711) that converts analog signal to digital signal and amplifies it and then sends data to the Arduino.

The height of the human body is calculated by the ultrasonic sensor. First, it emits ultrasound waves, and when those waves strike any object or person in its proximity, they are reflected back, which is sensed by the ultrasound sensor again. The height is calculated by multiplying the 'Speed of Ultrasound' and the 'Time taken by the Ultrasound' to return back to the sensor. The analog signal received from the ultrasonic sensor and load cell is further sent to the arduino, where calculation takes place. The calculation of BMI can be calculated with the help of given standard formula

$$\text{BMI} = \text{WEIGHT (kg)} / \text{HEIGHT (m}^2\text{)} \quad (1)$$

And then the result is sent to the display device.

The MAX30100 Pulse oximeter sensor is an integrated pulse oximetry and heart-rate monitor sensor solution. The device has two LEDs, one emitting red light, another emitting infrared light. For pulse rate, only the infrared light is needed. Both the red light and infrared light is used to measure oxygen levels in the blood. When the heart pumps blood, there is an increase in oxygenated blood as a result of having more blood. As the heart relaxes, the volume of oxygenated blood also decreases. By knowing the time between the increase and decrease of oxygenated blood, the pulse rate is determined.

The traditional thermometer is used for body contact for measuring temperature. On the other hand, the MLX90614 Infrared temperature sensor does not need any contact to measure temperature. There is a led/IR light for accurate targets for measuring temperature of objects. When the desired body or object is in the range of the thermometer then MLX90614 reads the temperature and shows it on display[8].

### III. COMPONENT USED

#### A. Arduino uno (ATmega328P)



Fig. 2 Arduino UNO

Arduino Uno is a microcontroller board based on an 8-bit ATmega328P microcontroller. Along with ATmega328P, it consists of other components such as crystal oscillator, serial communication, voltage regulator, etc. to support the microcontroller. Arduino Uno has 14 digital input/output pins (out of which 6 can be used as PWM outputs), 6 analog input pins, a USB connection, A Power barrel jack, an ICSP header and a reset button. It's frequency of operation is 16MHz. It has 14 digital input pins and 6 analog input pins. It has 5 volts operating voltage. And input voltage is 7 to 20 volts.

#### B. Load cell

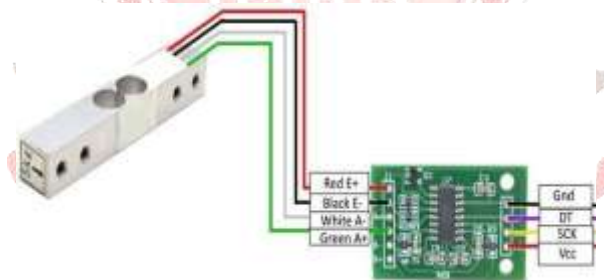

Fig. .3 Load cell with HX711 Module

The load cell is commonly used for the strain-gauge-based transducer. It converts an applied force (weight) into a bridge output potential. The 200Kg load cell to the arduino using HX711 Load cell amplifier Load cell has 4 pins which are connected to the HX711 amplifier module. Only 2 pins are needed (data and clock) for operation of the load cell using arduino. Other 2 pins are used for power. Its operating voltage is 5-10 volts.

#### C. HC-SR04 Ultrasonic sensor

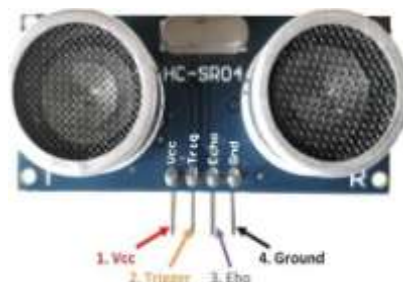

Fig. .4 Ultrasonic Sensors

HC-SR04 Ultrasonic (US) sensor is a 4-pin module, whose pin names are Vcc, Trigger, Echo and Ground

respectively. The module has the ultrasonic transmitter and Receiver. The sensor works with the formula that,

$$\text{DISTANCE} = \text{SPEED} \times \text{TIME} \quad (3)$$

The Ultrasonic transmitter transmits an ultrasonic wave, this wave travels in air and when it gets objected by any material it gets reflected back toward the sensor this reflected wave is observed by the Ultrasonic receiver module as shown in the picture above.

#### D. Pulse Oximeter Sensor (MAX30100)

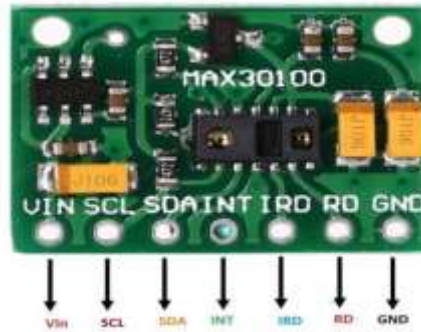

Fig.5 MAX30100 Sensors

The sensor is based upon Maxim's MAX30100, an integrated pulse oximetry and heart-rate monitor sensor solution. It combines two LED's, a photo detector, optimized optics, and low-noise analog signal processing to detect pulse and heart-rate signals. It operates from 1.8V and 3.3V power supplies and can be powered down through software with negligible standby current, permitting the power supply to remain connected at all times.

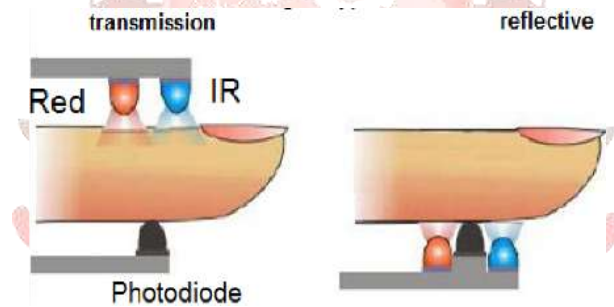

Fig. 6 Reflection of Pulse oximeter sensor

The MAX30100 sensor has two LEDs and a Photo-detector; the two LEDs are used to emit two different wavelengths of light. One led is a red led while the other one is an infrared led. The photo-detector is then used to sense the absorbance of the blood flowing through the fingertip. This signal is then processed using a low noise analog signal processing unit and then an internal micro-controller then converts it into digital output and gives out data in i2c protocol. MAX30100 Sensor Module has an inbuilt voltage regulator so it can be powered via 5 Volt and can be interfaced to any 5-volt micro-controllers.

#### E. Temperature Sensor (MLX90614)

The MLX90614 is a powerful infrared sensing device for non-contact temperature measurement with a very low noise amplifier and a 17-bit ADC. It enables high accuracy and resolution for the thermometer. The best part about the MLX90614 is it comes calibrated with a digital SMBus from the factory. This means that it will give an output with a high resolution of 0.02°C and can continuously transfer the measured temperature in the range of -20 to 120°C.

## IV. BATTERY BACKUP SYSTEM

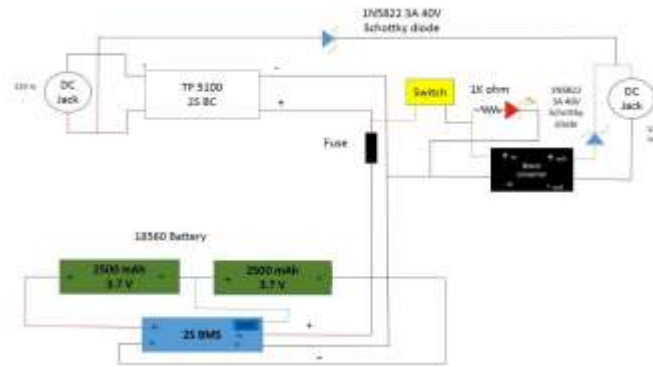

Fig.8 Block Diagram for Battery Backup System

A Battery backup provides power to a system when the primary source of power is unavailable. Backup batteries range from small single cells to retain clock time and date in computers, up to large battery room facilities that power uninterruptible power supply systems for large data centers. Small backup batteries may be primary cells; rechargeable backup batteries are kept charged by the prime power supply.

A. TP5100 Battery Charger



Fig.9 TP5100 Battery Charger

TP5100 is capable of charging a single lithium-ion cell or two lithium-ion cells wired in series at a time. It is a step-down switching double 8.4V / 4.2V single lithium battery charge management chip with built-in input overcurrent protection, under-voltage protection, over-temperature protection, short circuit protection, battery temperature monitoring, and reverse battery protection. This module can be used for 2A (usually 1.5A) charging of up to 2S Li-ion cells. As stated before, it can be used for charging a single cell (1S) or double cells (2S) wired in series.

B. XL6009E1

The XL6009E1 regulator is a wide input range, current mode, DC/DC converter which is capable of generating either positive or negative output voltages. It can be configured as either a boost, flyback, SEPIC or inverting converter. The XL6009 built in N-channel power MOSFET and fixed frequency oscillator, current-mode architecture results in steady operation over a wide range of supply and output voltages.

C. Boost Converter

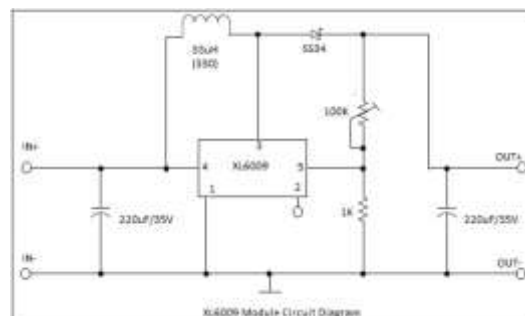

Fig. 11 Circuit diagram for boost converter

This DC-Dc switching boost converter is capable of driving a 4A load with excellent line and load regulation. The main switching component XL6009 IC is available in fixed output voltages of 3.3 V, 5V, 12V, and an adjustable output version. It is an efficient switching regulator and the output efficiency is high. At higher input voltages, the regulator operates at a switching frequency of 400KHz thus allowing the overall board size to be smaller and space-saving.

D. 2S Battery Management System



Fig. 12 2S BMS

A battery management system that is designed to monitor the status of batteries, control the process of charging/discharging the battery, etc. Two batteries (18650) can be connected simultaneously to the 2S battery management charge-discharge controller module. The module has protection against short circuit, overcharge, and over-discharge.

V. SEQUENCE OF OPERATION

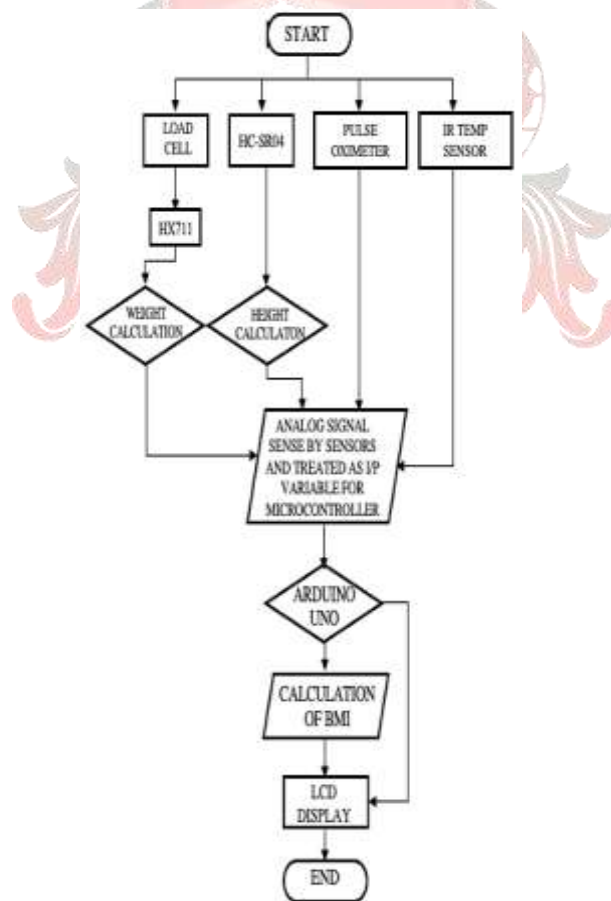

Fig. 13 Sequence of operation

## VI. SOFTWARE IMPLEMENTATION

The proposed project is implemented in Hardware. The 3D modelling is done in Solidworks Software Environment as shown in fig 14. The programming code for the arduino microcontroller which drives the operation of the system is written in 'C' language. Fig 13. depicts the flowchart of above programming code.

## VII. HARDWARE IMPLEMENTATION



When a person stands on platform, load cell and ultrasonic sensor senses the weight and height respectively, the heart rate and oxygen saturation level is measured by putting a finger on pulse oximeter sensor (MAX30100) and temperature of human body sensed by body temperature sensor (MLX90614), those output signals give to the arduino uno where arithmetic operations are take place and output of this device displayed on LCD screen.

## VIII. CALCULATION FOR BATTERY BACKUP SYSTEM

**Battery Backup:** - The Arduino UNO requires 7-12V and maximum current draw of the Arduino is 200mA. It is unlikely that the Arduino itself will draw 200mA but let's assume that between the Arduino and other devices connected to it, they draw a total of 200mA.

For a 18650 2400 mAh battery with a device that draws 200mA.

$$\text{Time} = 2.4\text{Ah}/0.2\text{A} = 12 \text{ hrs}$$

**Charging Time:** - The charging current ( $I_c$ ) of a Lithium-ion battery should not exceed 30% of the Ampere hour (AH) rating of the Battery.

$$\text{The charging current } (I_c) = 0.30 \times 2.4$$

$$I_c = 0.72 \text{ A}$$

The Time Required for full charging of battery = (Battery Capacity in AH) / (Charging current in Ampere)

$$\text{Time for Full Charging} = 2.4/0.72 = 3.33\text{hrs}$$

We consider 30% loss,

Due to heat dissipation losses, 30% time will be taken extra to change the battery

$$=23.33+0.99$$

$$=4.32 \text{ hrs.}$$

**i. Backup up to 12 hrs**

**ii. Charging Time 4.32 hrs**

**IX. RESULT**

| Sr. No | ACCURACY ANALYSIS     |        |                    |        |              |              |
|--------|-----------------------|--------|--------------------|--------|--------------|--------------|
|        | Measured with Sensors |        | Manual Measurement |        | ACCURACY     |              |
|        | Height                | Weight | Height             | Weight | Height       | Weight       |
| 1.     | 169.27                | 54.39  | 169                | 54     | 0.27         | 0.39         |
| 2.     | 171.30                | 62.22  | 171                | 62     | 0.3          | 0.22         |
| 3.     | 160.47                | 44.36  | 160                | 44     | 0.47         | 0.36         |
| 4.     | 168.55                | 80.66  | 168                | 80     | 0.55         | 0.66         |
| 5.     | 156.89                | 59.10  | 156                | 59     | 0.89         | 0.1          |
| Avg    | 165.29                | 60.14  | 164.8              | 59.80  | <b>0.496</b> | <b>0.346</b> |

Table no. 1 Accuracy of BMI

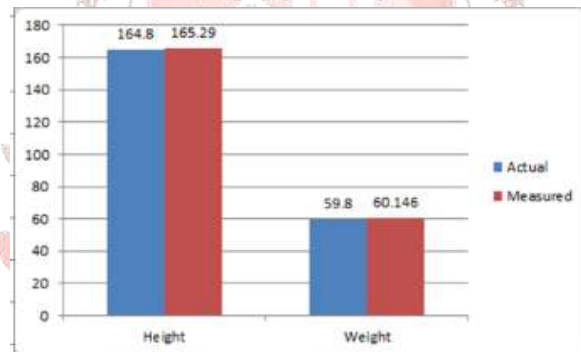

Fig. 17 Actual and Measured value of height and weight

**X. SURVEY**

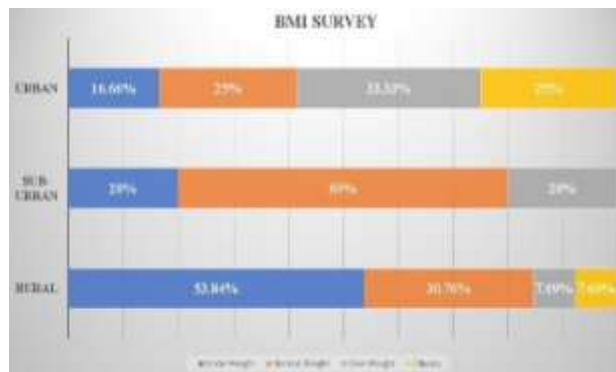

Fig. 18 BMI Survey

To test and prove the accuracy as well as precision of any designed system or a tool, Surveying plays a very important role. Therefore, the survey of 30 people is performed by using V Health plus. All 30 people who are

under surveying process are of different age groups, different body weights and located in different demographic regions as shown in fig.no. 11. The results of entire survey show that more than 50% people are underweight in rural area, on the other hand more than 30% are overweight and 25% are obese people are in urban area. As per the results of the survey, it is concluded that people are more conscious about their fitness so there are 60% people from sub-urban areas having normal weight.

## CONCLUSION

Nowadays people are getting more serious regarding their health. Most of us are aware about the significance of the health parameters such as SpO<sub>2</sub>, BPM, BMI, Temperature etc. It is just that people should be able to measure these parameters easily. V-Health plus exactly does the same. One can easily check the overall status of the body in very few seconds. The simplicity of this device makes it easily accessible. Due to its affordability common man can also reach this. As there are no invasive devices in V health plus hygiene is not that much concern. As V health plus comes with its own independent battery backup, it can be operated in most remote settlements which will help the health worker to educate those people which will ultimately help to grow Healthy Nation

This paper explains the proposed project of innovative approach towards measurement of human body parameters and analysis. Survey consists of data of various body parameter samples measured by V Health Plus Hence, V Health plus successfully measures Height, weight, BMI, Heart Rate, Oxygen saturation level and Body temperature and acts as a primary Human body monitoring device with calculated accuracy of **99.53%**.

## FUTURE SCOPE

Further interfacing with internet of things i.e. IoT, will provide increased independence and highest mobility. And also, by using raspberry pi, can add some other health parameters such as full body scan including blood pressure, blood glucose level detection, etc. And can be used as a diagnostic device.

## REFERENCES

1. World Health Organization: Use and interpretation of anthropometric indicators of nutritional status. Bull World Health Organ 64 (1986) 929– 941.
2. World Health Organization: Physical status: the use and Interpretation of anthropometry. Report of a WHO Expert Committee. World Health Organ Tech Rep Ser. 854 (1995) 1–452.
3. R. G. Landaeta, O. Casas, and R.P. Areny, “Heart rate detection from plantar bioimpedance measurements”, 28th IEEE EMBS Annual International Conference, USA, 2006, pp. 5113-5116.
4. Miguel Murguía-Romero<sup>1\*</sup>, Rafael Jiménez-Flores<sup>2</sup>, “Improving the body mass index (BMI) formula with heuristic search” in 2012 IEEE .
5. Md. Asaduzzaman Miah, Mir Hussain Kabir, Md. Siddiqur Rahman Tanveer and M. A. H. Akhand “Continuous Heart Rate and Body Temperature Monitoring System using Arduino UNO and Android Device ” Dept. of Computer Science and Engineering in 2015.
6. Heart Rate Monitors, July 17,2015  
<http://www.walmart.com/browser/sportsoutdoors/heartmonitors/412541341078104107814>
7. Anilkumar Kothalil Gopalakrishnan “Recommended Weight Prediction System Based on BMI, BMR, Food Calorie and a Neural Network” Technology, Department of Computer Science in 2017.
8. Md. A. Al Mamun, M. A. Hossain, M. M. Rahman, Md. I. Abdullah, Md. S. Hossain “Design and Development of Arduino Based Contactless Thermometer” Department of Computer Science and Engineering Islamic University, Kushtia, Bangladesh, June, 2020.