

PERFORMANCE ANALYSIS OF VAPOUR REFRIGERATION SYSTEM BY USING SPIRAL AND MICRO CHANNEL CONDENSER

¹Rutuja Awari, ²Shubhangi Badhe, ³Apeksha Lohote, ⁴Ashvini Shinde,
⁵Dr.Sarang Joshi

U.G. Student Mechanical Department, JSPM's, Imperial College of Engineering & Research, Pune, INDIA ^{1,2,3,4}, Professor Mechanical Department, JSPM's, Imperial College of Engineering & Research, Pune, INDIA ⁵

ABSTRACT

Most of the household refrigerators work on the Vapour compression refrigeration system which are holding high coefficient of performance. The system is assembled with the components like compressor, condenser, expansion valve and evaporator etc. The system performance is governed by each individual component being the part of that system and liable to take system performance up or down ultimately. The research article elaborates work about COP enhancement of domestic refrigerator by making alternative arrangement for condenser. The use of spiral and micro channel condenser raises COP of refrigerator to the value that was never before, the geometry, enhanced surface area of such micro channels are found adding positive results in the enhancement of COP value and work is elaborate through research work drafted in the paper. The results obtained through spiral and micro channel condenser installation are compared with conventional refrigerator and found worth appreciate. The COP enhancement through spiral and micro channel type condenser installation has noted down increased by 5.06% and 13.82% respectively. The base value considered in the comparison is COP of domestic refrigerator with regular condenser system inbuilt.

Keywords: COP, Micro channel, Vapor compression refrigeration.

INTRODUCTION

Most of the domestic and commercial refrigerators are operates on 'Vapor-Compression' cycle and run for normal COP value which holds the scope of improvement with alteration made in components assembled in system. Figure 1 shows the schematic diagram of components for typical vapor-compression refrigeration system. In the thermodynamics cycle, a circulating refrigerant such as Freon enters the compressor in vaporized form [1].

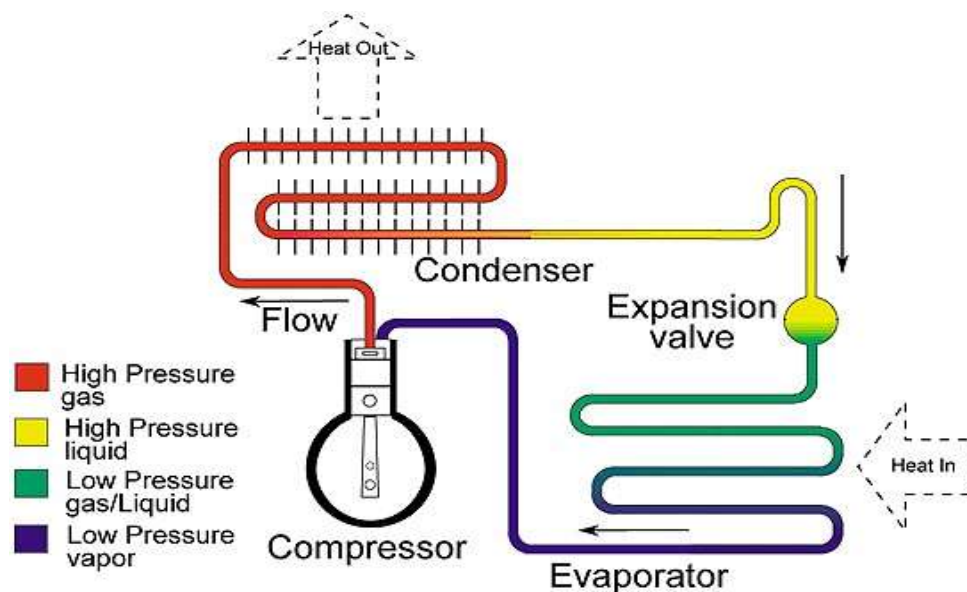

Fig. 1 Architecture of VCR System [1]

From point 1 to point 2, the vapor is compressed at constant entropy and exit compressor as a vapor which holding very high temperature. From point 2 to point 3 and further to point 4, the vapor travels through condenser which cools the vapor until it starts condensing, and then condenses the vapor into a liquid by removing additional heat at constant pressure and temperature. In between points 4 and 5, the liquid refrigerant goes through expansion valve/Throttle valve, where its pressure decreases abruptly, causing flash evaporation and autorefrigeration of less than half of the liquid. It further results in forming mixture of liquid and vapor at the lower temperature and pressure as shown at point 5 [7]. The cold liquid-vapor mixture then travels through the Evaporator coil and get vaporized by cooling the warm air, being blown by fan across the Evaporator coils or tubes. The resulting refrigerant vapor returns back to the compressor inlet at point 1 to complete the thermodynamic cycle and so on. The discussion taken place is centric about idle vapor-compression refrigeration cycle, and does not account real-time effects like frictional pressure drop in the system, thermodynamic irreversibility during compression of the refrigerant vapor, and non-ideal gas behavior which come occurred all of them or in the set of few leading to deviate refrigerator performance from idle one and impact of which can be viewed in terms down value of COP [7].

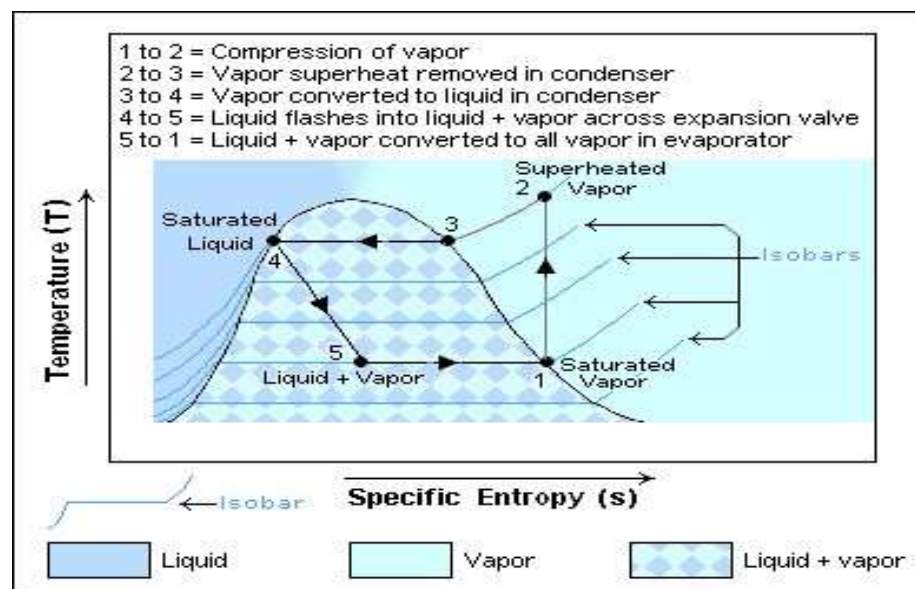

Fig. 2 Idle Vapor-Compression Refrigeration cycle [7]

In vapor compression refrigerating system basically there are following types of heat exchangers used.

- One, which absorbs the heat by means of evaporator
- Second, which removed absorbed heat from refrigerant and added heat of compression and condenses it back to liquid [4]

It comes to attract an attention about condenser performance which leading to increase COP of overall refrigerator system. And thus project work is shaped, replacement of domestic refrigerator provided with regular condenser by spiral and micro channel type condenser to study percentage of enhancement come occurred in COP as an outcome [2][6].

EXPERIMENTAL WORK

The condenser is one of most important component of Vapor compression refrigeration system which contributes lot in the overall system performance. Effectiveness of its working through rigged control taken over various performances affecting attributes correlate to it, delivers the worth accepted results at minimum possible cost expenditure.

As function of Condenser is dissipating the heat absorbed by refrigerant during the process of evaporation and compression. The refrigerant COP is the function of its operating temperature, the current work undertakes modification of condenser geometry and thus through effective temperature regulation maintained, system COP would be high. The project work is centric about, installation of spiral and micro channel shape base condenser to the refrigerator holding 165 Liters capacity. The refrigerator with spiral and micro channel shape condenser, put in to the service is shown below,



Fig. 3 VCR installed with Spiral condenser and Microchannel condenser

Table 1 Specifications of the condenser

Parameters	Existing Condenser	Spiral Condenser	Micro channel Condenser
Diameter of coil	6.35 mm	6.35 mm	0.9 mm
Spacing	42 mm	45 mm	42 mm
No. of Turns	8	5	8
Length of coil	5320 mm	5320 mm	5320 mm
Height	595 mm	595 mm	595 mm

3. EXPERIMENTAL PROCEDURE

The following procedure is intended to build an experimental set up for Vapor compression refrigeration system.

- Domestic refrigerator working on Vapor compression cycle and holding capacity (165 Liter).
- Pressure and temperature sensors are fixed at the point of compressor entry and exit too. Additional temperature sensor is fixed at the evaporator.
- System flushing is executed through pressurized Nitrogen gas.
- Conventional condenser replaced by Spiral and micro channel shape base condenser.
- R-600 refrigerant is charged in to VCR system

- Switch ON the refrigerator system and observations are noted from Pressure gauge and control panel for respective temperature readings.
- The performance of the existing system, Spiral system and micro channel condenser system is investigated with respect to set of observations in terms of Temperature and pressure readings obtained.
- COP discussed system is investigated with the help of P-H chart
- The results are tabulated for Existing, Spiral and micro channel condenser based system

RESULTS AND DISCUSSIONS OF THE STUDY:

The replacement of conventional refrigerator system by spiral and micro channel shape condenser shows enhanced work capability every time added with worth appreciate result and thus following discussion can be added to work further on the system its performance to improve beyond its current working capacity. The discussion in the context can be added as follows,

Optimization head	Result improvement found	Scope of further improvement
Condenser geometry	COP found increased with geometry altered to Microchannel and spiral type	With alteration made in condenser geometry the space compactness can be considered to reduce further.
Pitch of coil	Heat rejection to surrounding found increased with respect to increased pitch value	Pitch of coil reduced further to support compactness in the structure without compromising rate of heat rejection and thus ultimately refrigerator COP
Surface area	Heat rejection found maximum with respect to increased surface area	Beyond one limit, surface area added adverse effect and thus its value supposed to so maintain, without affecting COP, the rate of heat rejection to surrounding will address as smooth as required.

Table 2 Result table obtained with respect to observation noted down and calculations performed

Parameters	Condenser		
	Existing Condenser	Spiral Condenser	Microchannel Condenser
COP	2.17	2.28	2.41
Net refrigeration Effect	160	183	205
Mass Flow rate to obtain 1TR	1.31	1.14	1.02
Compressor work (KJ/Kg)	73.73	80	85
Heat rejected in condenser KJ/Kg	260	263	290
Compression pressure ratio	11.86	12.11	12.75

4.1 Effect of type of condenser on the COP

Fig 5 shows the effect of type of condenser on the COP. From the figure it has been observed that domestic refrigerator gives better performance when Microchannel condenser is used.

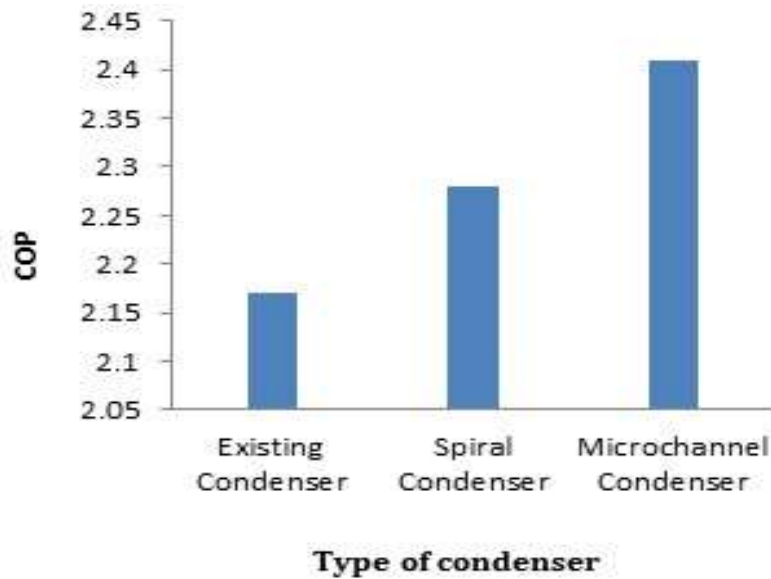

Fig. 5 Effect studied between type of condenser and respective COP obtained

4.2 Effect of type of condenser on the Mass Flow rate

From figure 6 it was observed that when we use microchannel instead of using existing and spiral condenser there is a considerable reduction in mass flow rate of refrigerant per TR.

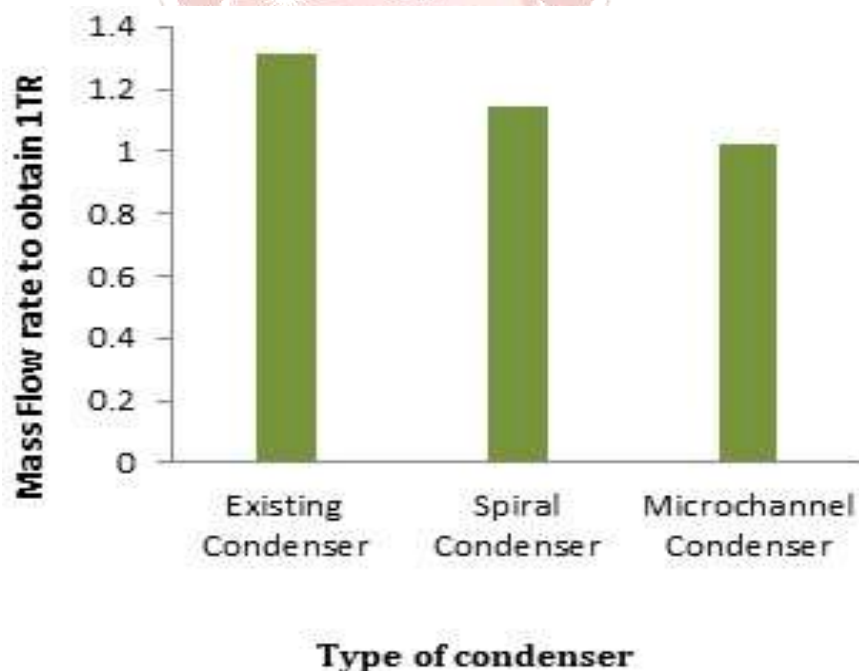

Fig. 6 Type of condenser recommended in to operation vs. Mass Flow rate to achieve 1TR

4.3 Effect of type of condenser on the rate of Heat rejection to surrounding

Above figure shows the heat rejection rate for the different types of condenser. It is seen that Microchannel condenser has maximum heat rejection of 290 KJ/Kg than other two types.

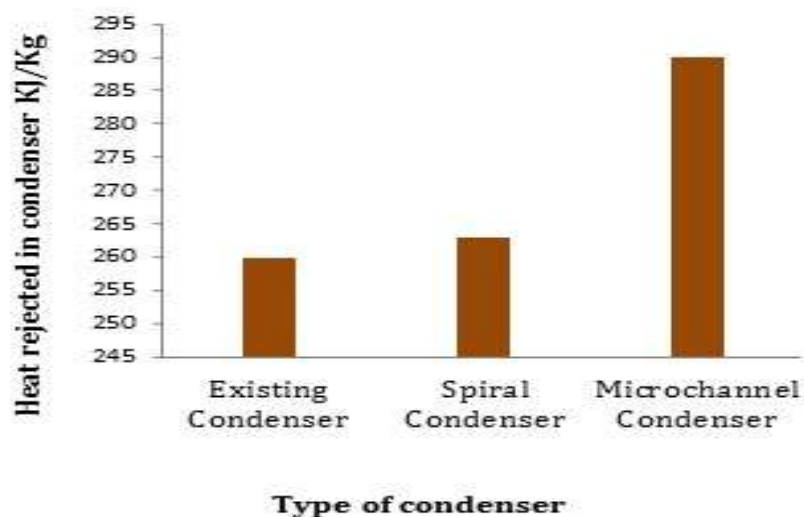

Fig. 7 Effect studied between type of condenser in service and rate of heat rejection to surrounding

CONCLUSION OF THE STUDY

The current work is centric about performance study of spiral and micro channel shaped condenser used in refrigerator holding 165 liters' capacity. The data obtained from fabricated experimental set up used in analyzing performance of spiral and micro channel shaped condenser used as a part of vapor compression system. With introduction made for spiral and micro channel shape condensers, \square COP value found increased by 5.06 % and 13.82 % respectively over the conventional refrigeration system.

- When spiral condenser is replaced by micro channel there is increase in refrigeration effect and compressor work by 12.02 % and 6.25 % respectively with increase in rate of heat rejection considerably.
- The summarized observations made has verified the performance of Micro channel shape base condenser and so the refrigeration System has better performance over conventional refrigeration system supported with regular shape condenser.

REFERENCES

- [1] B. Santosh Kumar. (2015), Experimental Investigation of Vapour compression system with Spiral shaped condenser, IJRME,02, pp.1114.
- [2] Pravin lohote and Kolhe K.P. (2016) Review on Performance analysis of Vapour Compression Refrigeration System by using Microchannel heat exchanger JETIR 3(4)pp 202-206.
- [3] Pawankumar, Kolhe K.P, and C. K. Datta "Study of effect of pulse process parameters on GTAW process on AA aluminum alloy 7039. International Journal of Engineering and technology in India. ISSN-0976-1268 2010, 1 (2), Pp.61-67.
- [4] Francisco julio do Nascimento (2013) An experimental study on flow boiling heat transfer of R134 A in microchannel based heat sink, Science direct,45, pp.117-127.
- [5] Seunghyun Lee (2016), Investigation of flow boiling in the large microchannel heat exchanger in a refrigeration loop in space application, Science direct, 97 pp.110-129.
- [6] Huize li (2015) An experimentally validated model for microchannel heat exchanger incorporating lubricant heat effect, Science Direct, 59, pp.259-268.
- [7] R.S.Andhare (2016),Heat transfer and pressure drop characteristics of a flat plate manifold microchannel heat exchanger in counter flow configuration. Science Direct,96, pp178-189.
- [8] Abdul Kareem R.Abed (2014),Experimental study on the effect of Capillary tube geometry on the performance of Vapour Compression refrigeration System ,Diyala Journal of Engineering science,07,pp 47-60
- [9] R.Hussainvali,(2015),An experimental investigation and performance evaluation of vapor compression refrigeration system with Helical type condenser by using R134 A and R140A refrigerant, IJERST,4,pp.192-201.

- [10]Jala Chandramauli, (2015), Design, application and experimental analysis of vapour compression refrigeration system with Ellipse shaped evaporator coil, IJRSET,4. pp.7775-7782.
- [11]Jaeseon Lee (2009), Low temperature 2 Phase microchannel cooling for high heat flux for thermal management of defense electronics, IEEE,32, pp.453-465
- [12]Ashish Wankhade and Kolhe K. P. (2015) “ Design and Analysis of Hydraulic Oil Cooler By Application of Heat Pipe. International Journal of Science Engineering and Technology Research 4(9) Pp.3189-3194.

