

ADAPTATION AND EVALUATION OF CHARCOAL KILN METAL FOR CARBONIZING KHAT WASTE, STICKS AND LEAVE

Gutu Getahun

Oromia Agricultural Research Institute, Fedis Agricultural Research Centre P.O. Box 904, Harar, Ethiopia.

gutugethun@gmail.com

ABSTRACT

Experiment was carried out to obtain the more charcoal and decreased ashes and exhaust gas after production from khat wastes, sticks and leave. In this study volume-based conversion rate was investigated with three different loading mechanism, half carbonizer load, 75% carbonizer load, Full carbonizer load. Product from charcoal kilns consists of weight of charcoal, ashes and gas exhaust from process. The charcoal was produced in 2.14 m³ of the vertical drum kilns when it is fully loaded. The results indicated that weight of charcoal increased when it was fully loaded, 75% carbonizer load, and half carbonizer load respectively. Whereas the weight of ashes also decreased when it was fully loaded, 75% carbonizer load, and half carbonizer load respectively. The averages of temperature of the kilns for different position of the flue outside and inside of the kilns were also taken. The results showed that the average of temperature both the flue outside and the flue inside of the kilns obviously increased with increasing time. The maximum temperatures of the kiln were 836 °C inside the pyrolysis chamber and 309°C on the outer surface of the kiln. It can be observed that the temperature of the flue outside increased from 26.7°C to 309°C with increasing time up to 90 min and then decreased from 309°C to 86 °C and from 90 min to 170 min. Moreover, the temperature inside the pyrolysis chamber increased from 26.7 °C to 836 °C with increasing time up to 90 min and then decreased from 836°C to 98.7°C) and from 90 min to 170 min. Therefore, the results of this technology can help in encouraging use of khat waste as substitute to wood charcoal that could contribute in minimizing deforestation and consecutive climatic changes.

Key words: *khat waste, carbonizer, kiln and charcoal*

INTRODUCTION

Biomass is plentifully available in the rural regions Ethiopia. It is already being used by the rural people as a major source of energy, mainly in cooking food, which constitutes almost over 90% of the total energy consumption [14]. Assuming that the population of Ethiopia are about 82 million in Ethiopia [3], 90% of the population in Ethiopia lives in rural area [6], and assuming that each family consists of five persons and uses annually about 3 tons of biomass as fuel, one comes to the figure of about 44.28 million tons of biomass utilized annually only for domestic cooking in rural areas only. The urban populations of Ethiopia (10%) are also using biomass and assuming that 78% of the urban population uses this biomass as a fuel, one comes to the figure of 3.84 million tons of biomass as fuel.

In Ethiopia many parts of the country, charcoal is produced from the wooden trees which causes deforestation and, environmental degradation which is a serious issue of current situation on climate change. The usage of energy from biomass, most commonly obtained through fire. The energy from agricultural waste biomass (crops, grass, residues, etc) can be harnessed through the process of combustion, which allows the material to be carbonized. Agricultural waste is an ideal source of charcoal. When one harvests any crop, one generally harvests only grain, fruits, coffee, pods, and tubers. This constitutes only about 30 to 40% of the total biomass. This means that about 60 to 70 % of the total agricultural biomass is the waste biomass produced annually in Ethiopia [15]. There are many options used to produce charcoal such as; agricultural residues, stalks, chaffs and fallen leaves.

In Eastern part of the country, harvesting of grain generates massive amounts of agricultural waste, including maize and sorghum stalk, khat leaves and its stem/stalk residues and maize cobs which is used as fuel or energy source for cooking or food preparation. Some of crop residues (maize and sorghum leave and stalk are used as fodder for cattle, but unnecessary khat stem and leaves are collected or accumulated as wasted. However, the khat waste is high than other crop residues, no and study is not done over this waste management [12]. Khat plants are grown among crops such as sorghum, maize, and legumes and sweat potato in hararge.

In Ethiopia, especially east Hararge, khat is an important and potentially profitable cash crop. The employment opportunity created through the cultivation of khat is very high in that large numbers of people are involved in growing, harvesting, sorting, packing, transporting, loading and unloading the commodity [7]. According to [7] approximately 50 tons of khat and its related materials per day reach the market in summer whereas relatively the production is lesser in winter times.

However, in the summer the municipality has been collect 6-8 car of solid waste of khat. From this observation [7] was conclude that about 15-20tons of solid waste is produced every day only from Aweday town and till know this solid waste hasn't any solution. If these wastes have not managed properly, negative impacts Environmental and human health. Hence thinking of alternatives solution for these problems by using existing technology is necessary, one is conversion of agro- wastes into charcoal which reduces effect of deforestation or the uses of wood charcoal. Providing a biomass as an alternative to wood charcoal using agricultural wastes converted into charcoal to provide much needed source of cheap fuel that is cleaner in burning. A promising alternative to burning is carbonization hence the aimed this study was to adapt and evaluate appropriate kiln metal (carbonizer) of khat waste, sticks and leave.

MATERIALS AND METHODS

Study area description

The site and farmer selection were done based on potential area of Charcoal production potential from east hararge zone. Then evaluation and collecting of full data was done on the selected site.

Important materials that are required for manufacturing of khat waste carbonization was identified & selected based on the design specification. According to this, sheet metals, round bar for handling and deformed bar, Carpet, Oven, Thermometer, Bomb Calorific, Briquette Stove, Pan, Stop watch, Digital Balance and khat wastes were among materials used for carbonization process. All raw khat wastes utilized in this experiment were collected and obtained from Aweday town.

Manufacturing of Carbonizer (kiln metal)

After design specification was done, Manufacturing of Carbonizer (kiln metal improvement of carbonization technology was performed and continued. The kiln consists of two interlocking cylindrical sections. The bottom section is made from 3mm sheet metal, 1.27m in diameter and 1m high. The second section is made from 3mm sheet metal, 1.24m in diameter and 0.6m high. Its conical cover is also made from 2mm sheet metal. The kiln rests up on six 0.1 x 0.20m box channels, each about 0.5m long with closable vents and collars. It has three smock stacks 0.105m diameter and 1.8m high. The kiln has a capacity of 2.14m³ of wood. Advantages besides its good performance are that it easily can be manufactured locally, and that it can be disassembled and transported.

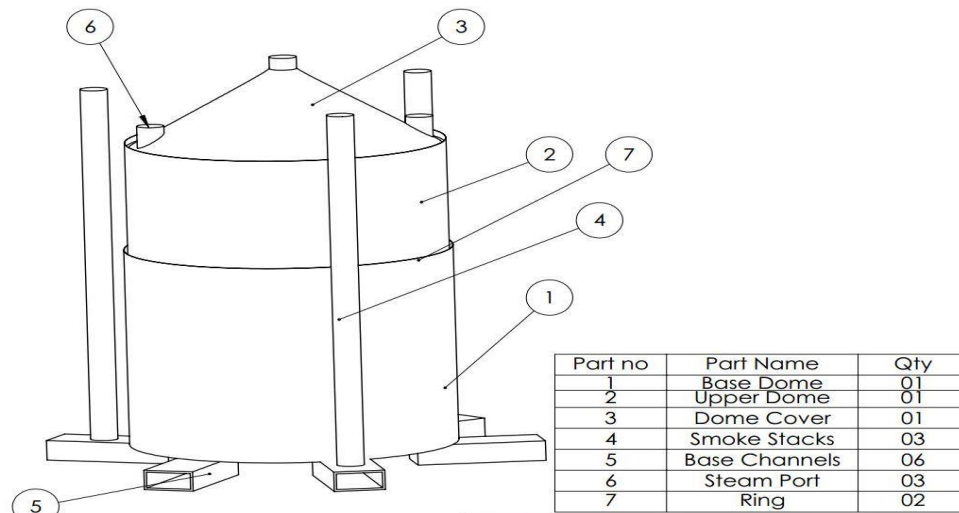

Figure 1. Charcoal kiln metal 3D View

OPERATION OF METAL KILN CARBONIZER

The carbonization experiment was carried out using the cylindrical carbonization kiln using three batch loading methods. These were fully (100%), 75%, 50% loading method to the kiln and introduced in to the drum and charred with a match to start ignition to identify the effect of loading method on its burning efficiency. To supply the necessary heat and pyrolysis the khat waste, a controlled amount of air was supplied from an outside through three smoke stacks and 6 box channels with closable vents and collars. A gate valve and a flow meter was installed along the connecting pipe for regulating and measuring the amount of air introduced in to the drum. K-type thermocouples installed at bottom, were used to monitor the progress of the bed temperature (both heating and cooling) for every 10 minutes. Moreover, an Infrared thermometer was also used to measure the external temperature distribution of the drum. Khat waste carbonizer was set in their working condition and then fuel material has been fed to reactor in batch to certain height of the drum. A fire ember was prepared outside the drum to be distributed over fuel material provided in carbonizer. After fuel reached required height, fire ember or glow were distributed evenly over raw fuel in order to facilitate carbonization activity per each batch. At the start of the carbonization process integrated part of exhaust chimney and air vent was left open for the volatile gases to escape. Enhancement of carbonization had been checked up throughout activity with the changing of the color of the smoke from white to none. The drum was closed eventually after application of the last batch & change of the color of smoke has been checked up via upper air vent. The biomass material was left to carbonize for 90 to 170 minutes. When the smoke releasing ceased or after it becomes colorless, top most lid that was integrated with chimney locked down and water jacketed. After these all process, the carbonized product was removed over prepared carpet to further cool and safely collects charred khat waste. The products were carefully withdrawn from reactor to further reduce damage. From this, charred product and uncharred khat waste were identified, sorted out and recorded. Weight of burned and unburned charred khat wastes was measured to estimate the quality and quantity of the charred products. In doing so data were collected, processed and analyzed carefully employing standard data analysis tool to mark out or predict the performance of khat waste carbonization.

DATA ANALYSIS

The proximate analysis of the raw material (moisture content, ash content, volatile matter content, and fixed carbon content) is conducted following ASTM D-standards. All proximate analysis of the produced fuel briquette

includes moisture content; Volatile matter content, ash content and fixed carbon content are carried out in the Federal Rural Energy design and Promotion center laboratory.

The equations for actual recovery, maximum recovery and Carbonizing efficiency are presented in Eqs (1), (2) and (3), respectively [14]

$$R_{actual} = \frac{W_{charcoal} \times 100}{W_{initial}} \quad * (1)$$

Where:

R_{actual} is the actual recovery of the system (%)

$W_{charcoal}$ is the weight of charcoal recovered (kg)

$W_{initial}$ is the initial weight of samples (kg)

$$R_{max} = \frac{W_{initial} - W_m - W_{vm} \times 100}{W_{initial}} \quad * (2)$$

R_{max} is the maximum recovery of the system (%)

$W_{initial}$ is the initial weight of wet samples (kg)

W_{vm} is the weight of the volatile matter (kg)

W_m is the weight of water in the sample (kg)

$$E_{Carbonizing} = \frac{\text{Total charcoal output} \times 100}{\text{Total Waste input}} \quad * (3)$$

Where E_{Carbo} : is the Carbonizing efficiency (%)

RESULT AND DISCUSSION

Table1. Data collected and analyzed

Parameters	Loading mechanism		
	50%	75%	100%
Total time of operation	170min	170min	170min
Ignition time	3	3.12	3.43
Moisture	8.5	7	9
Khat waste (kg)	36.4	54.21	72.28
Charcoal (kg)	13.86	21.25	30.35
Unburned char (kg)	2.19	3.94	7.49
Ash content (kg)	1.63	1.42	1.02
The actual recovery of the system (%)	38.08	39.2	42
The maximum recovery of the system (%)	55.4	56.8	58
The system efficiency (%)	68.74	69.01	72.41

In this study volume-based conversion rate were investigated with three different loading mechanism half carbonizer load, 75% carbonizer load and full carbonizer load. Product from charcoal kilns consists of weight of charcoal, ashes and gas exhaust from process. The charcoal was produced in 2.14 m³ of the vertical drum kilns when it is fully loaded. The results indicated that weight of charcoal increased when it was fully loaded, 75% carbonizer load, and half carbonizer load respectively. Whereas the weight of ashes also decreased when it is fully loaded, 75% carbonizer load, and half carbonizer load respectively. The averages of temperature of the kilns for different position of the flue outside and inside of the kilns are also taken. The results showed that the average of temperature both the flue outside and the flue inside of the kilns obviously increased with increasing time. The maximum temperatures of the kiln were 836 °C inside the pyrolysis chamber and 309°C on the outer surface of the kiln.

Temperature distribution inside and external pyrolysis

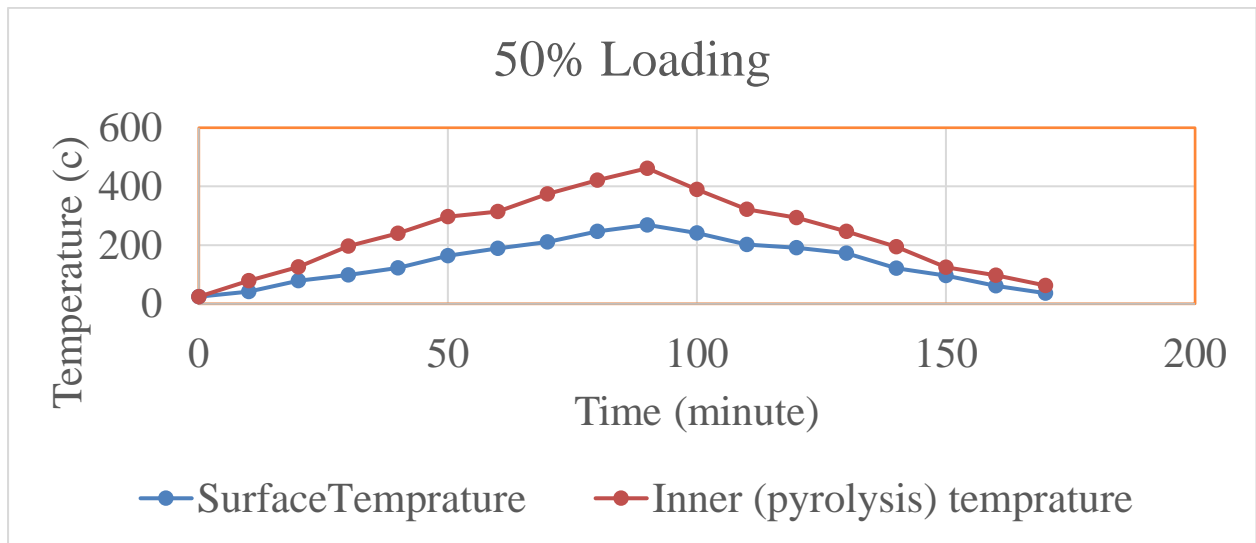

Figure 2. shows temperature distribution inside and external pyrolysis at 50% loading during combustion

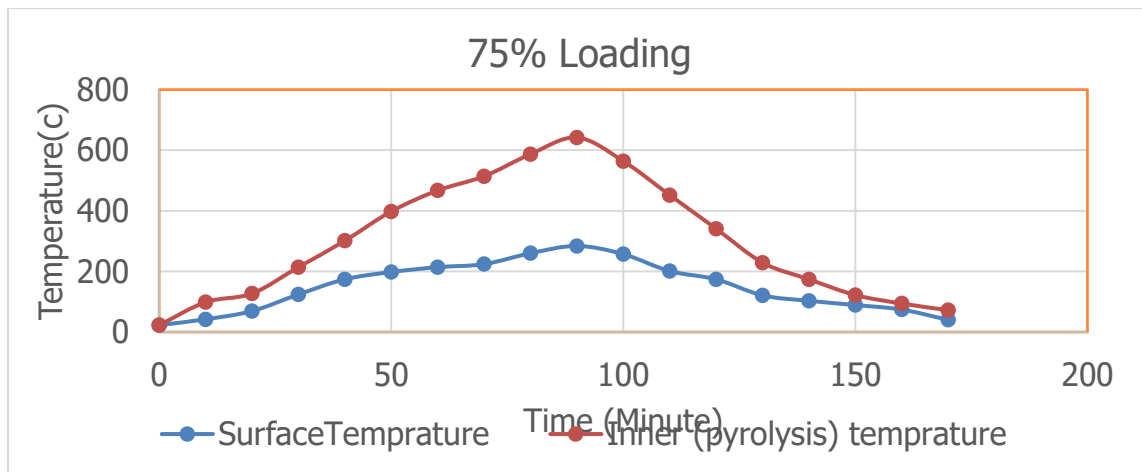

Figure3. shows temperature distribution inside and external pyrolysis at 75% loading during combustion

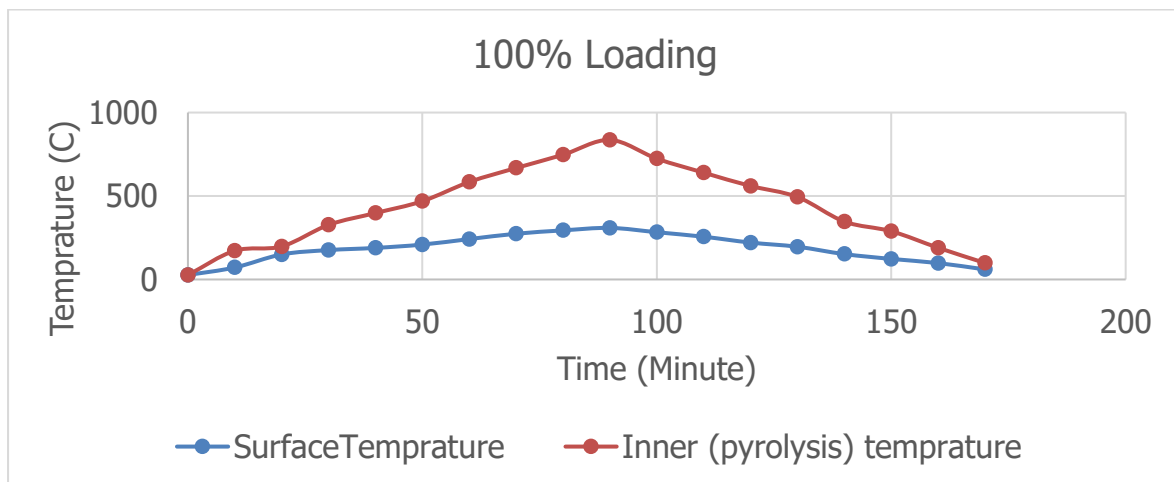

Figure 4. shows temperature distribution inside and external pyrolysis at full loading during combustion. It can be observed that the temperature of the flue outside increased from 26.7°C to 309°C with increasing time up to 90 min and then decreased from 309°C to 86 °C and from 90 min to 170 min. Moreover, the temperature

inside the pyrolysis chamber increased from 26.7 °C to 836 °C with increasing time up to 90 min and then decreased from 836°C to 98.7°C) and from 90 min to 170 min. The results showed that Bio char is a predominantly stable, recalcitrant organic carbon compound, which can be obtained when biomass is heated to temperatures usually between 300 °C and 1000 °C, under low (preferably zero) oxygen concentrations [5]. But the result gave the good trend in the pyrolysis process because one of the pyrolysis conditions for the high production of charcoal yields was the pyrolysis temperatures less than 1000 °C and this explanation was in line with [5].



Figure 5: shows Photo taken during Combustion and Unloading

PROXIMATE ANALYSIS

Table below illustrated the mean values of proximate analysis of the carbonized khat waste. The analysis included fixed carbon, volatile matter and ash contents of khat waste sticks and leave involving three different loading mechanism. The quality determining parameter of charcoal produced from biomasses expressed in terms of proximate analysis and physical properties [10], So these parameters are moisture content (MC), volatile matter (VM), ash content (AC), fixed carbon content (FC), calorific value (CV), were collected to decide for utilization.

Table2: Laboratory test Result

SN.	Sample type	Moisture Content (%)	Volatile matter (%)	Ash Content (%)	Fixed Carbon (%)	Calorific Value(cal/g)
1.	Khat Raw (50%)	8.5	76.5	2.5	12.5	4145.98
2.	Khat Raw (75%)	7	75.5	3	14.5	4254.52
3	Khat Raw (100%)	9	74.35	1.5	15.15	4376.78
4	Khat Charcoal (50%)	6.5	41	5.5	47	5442.8
5	Khat Charcoal (75%)	6.5	35	7	51.5	6414.9
6	Khat Charcoal (100%)	5.5	31.5	6.5	56.5	6513.86
7	Kacht briquette with clay binding	7	16	18	59	4778
8	Kachat briquette with paper binding	12	42	12	34	5595.9

As expressed on table 2 above the moisture content of charcoal produced from khat waste were lower than the moisture content of charcoal produced from wood which has moisture content of 12% [9]. The result shows values of moisture content are between 5.5 - 6.5. The quality specification of charcoal usually limits the moisture content between 5 to 15% [4]. Similarly, the volatile matter of charcoal in this study is lower than the volatile matter of charcoal produced from Coconut and rice husk residue charcoal which have the matching values of 71 [10]. The higher the volatile matter implies the faster will be the ignition but with high smoke [13]. The result shows values of volatile matter 31.5, 35, 41, when they are 100%, 75%, 50% loading respectively. The high fixed carbon content gives the result of high calorific value [4]. It seems true where the charcoal produced from khat had higher fixed carbon content of 56.5 and 41 and had the higher gross calorific value of 6513.86 and 5442.8 cal/g when they loaded 100%, 50% respectively. Calorific value determines the energy content of a fuel and it is the property of biomass fuel that rely on the chemical composition and moisture content of the material [12]. As shown in above table for calorific value of the produced charcoal which increase in similar manner with that of its fixed carbon content. The results indicated that the calorific value of charcoal increased when it is fully loaded, 75% loaded, and half loaded respectively i.e 6513.86, 6414.19, 5442.8 (cal/g) respectively.

CONCLUSION AND RECOMMENDATIONS:

This first test on the pilot kiln is a successful step towards new kilns has the following main advantages:

Simple has no mechanical or electrical components and the design is flexible can be locally manufactured in mass production in suitable sizes by local materials. Saving time and requires minimum control and/or observation of kiln working conditions. Efficient has a high charcoal yield with minimum partial wood burning at the initial stages. Economic: suitable capitals cost and low running cost so it is a simpler and more economical alternative to a traditional carbonization process.

Has low environmental impact: The gases and vapors evolved as a by-product during this process did not send to the atmosphere as dangerous pollutant but it used as an energy source for the process. No Tars, organic liquids and other condense yield because they are kept at high temperature to the burning area before condensation. It is comparatively medium in size and can be dis assembled and transported from a place to place. The improved kiln described and tested in this study needs additional efforts and support to be manufactured in mass production and to be introduced to the market.

ACKNOWLEDGEMENTS

I would like to thank Oromia Agricultural Research Institute and Fedis agricultural research center for financing and supporting the research. I am also most grateful to my colleagues who involved in research field work and prototype manufacturing.

References

- [1] A. D. Karve, "Biomass as energy source (appropriate rural technology)", India, August 27, 2005
- [2] Bouros D. and Samiou Maria F., Short-term effects of wood smoke exposure on the respiratory system among charcoal production workers, ISSN 0012-3692
- [3] Claudia Sori, Ethiopiademographics profile, Source: CIA World Fact book Retrieved from http://www.indexmundi.com/ethiopia/demographics_profile.html, December 18, 2008.
- [4] FAO (Food and Agriculture Organization), (1985). Industrial charcoal making., FAO Forestry Paper No. 63, Rome, Italy.

- [5] Frank Verheijen (2010). Biochar Application to Soils – A Critical Scientific Review of Effects on Soil Properties, Processes and Functions
- [6] Gebremedhin <http://www.bioenergylamnet.org/publications/source/mex/PPT-WG4-3-LAMNET-WS> Morelia, 3rd Issue (June 2003)
- [7] Mahabub Yusuf, 2008, composting of khat and related materials as solid waste management option in awaday town.
- [8] Malatji,P., Mamphweli,N.S. and Meincken,M., (2011). The technical pre-feasibility to use briquettes made from wood and agricultural waste for gasification in a downdraft gasifier for electricity generation. *Journal of Energy in Southern Africa*.Vol. 2, No.4: pp.1-7.
- [9] Mekonnen, A. 1999. "Rural Household Biomass Fuel Production and Consumption in Ethiopia: A Case Study". *Journal of Forest economics* %(1): 69-79.
- [10]Murali, G., Channankaiah, Goutham, P., Hasan, E.I., Anbarasan, P. (2015). Performance Study of Briquettes from Agricultural Waste for Wood Stove with Catalytic Combustor.*Int.J. ChemTech Res.*,Vol. 8, No.1:pp.30-36.
- [11]Oladeji, J., (2010). Fuel Characterization of Briquettes Produced from Corncob and Rice Husk Residues. *The Pacific Journal of Science and Technology*, Vol. 11, No.1:pp.101-106.
- [12]Raju, Ch. A., Satya, M., Praveena, U. and Jyothi, K. R., (2014). Studies on Development of Fuel Briquettes Using Locally Available Waste. *Int. Journal of Engineering Research and Applications*.Vol.4:pp.553-559.
- [13]Sotannde OA, Oluyeye AO, Aba GB (2010). Physical and Combustion of Charcoal Briquettes from NeemWood Residues. *Int. Agrophysics*, 24:189-194.
- [14]Virgilio S. MORALES, Jessie C. ELAURIA and Marilyn M. ELAURIA Carbonization of Young Coconut (*Cocosnucifera*) Wastes *J. Jpn. Inst. Energy*, Vol. 94, No. 10, 2015
- [15]WondwossenBogale 2009.Preparation of charcoal using agricultural wastes. *Ethip. J. Educ. & Sc.* Vol. 5 No 1 Mechanical Engineering Department, Jimma University, Jimma, Ethiopia