



ALGORITHMS FOR SOLVING PROBLEMS OF MANAGING A PRODUCTION UNIT WITH A DISCRETE UNIT TYPE OF PRODUCTION

I. I. Kalandarov

Ph.D., associate Professor Nukus branch of Navoi state mining
ilyos1987@mail.ru

ABSTRACT

For operational management of the shop, the main tasks are planning the loading of equipment with different planning horizons (ten days, five days, a day). However, these tasks are addressed to the existing structure of production units to the result of the solution is not always obtained satisfactory, since the nature of the control object is different, which leads to uneven loading of the production capacities of the workshop and the appearance of "narrow" jobs and capacity reserves. In this work the problem of the organization of specialized work places is considered on the basis of the analysis applied at machining of rigging and the algorithm of its decision is offered.

INTRODUCTION

The task of organizing specialized jobs. The problem of the organization of workplaces (WP) can be solved in various ways. One way is to optimize the spatial structure of production units [1,3].

Formulation of the problem. The workshop has a monthly production program. It is required to organize specialized WP (with a certain tool for processing parts) in order to increase labor productivity and efficient use of production facilities.

Mathematical model of the problem. There is a set of PM:

$$R = \left\{ R_i^{kj} \mid i=1, \overline{S}, k=1, \overline{K}, j=1, \overline{J} \right\},$$

where R_i^{kj} - j - e PM of the k the group of process equipment (GPE) of the i-the site. Where in

$$R_i^{kj} = \left\{ \Phi_i^{kj}, T_i^{kj} \right\}$$

Here Φ_i^{kj} is the available time fund of the j-the PM of the k-the GPE of the i-the site; - labor intensity of the operations performed at the j-the PM of the k-the GPE of the i-the site; in its turn

$$T_i^{kj} = T_i^{kj} + T_i^{kj}$$

Where T_i^{kj} is the time for processing the parts on the j-m PM k-the GPE of the i-the site, T_n^{kj} - the time of readjustment to the j-m WP k-the GPE of the i-the site.

A lot of the snap used in order processing are:

$$Q = \left\{ Q_n^{km} \mid n=1, \overline{N}, k=1, \overline{K}, m=1, \overline{M} \right\}$$

where is Q_n^{km} the -m-the rigging of the k-the operation of the n-the order, and $Q_n^{km} = \left\{ T_{n_{nH}}^{km} \right\}$. Here

$T_{n_{nH}}^{km}$ is the time for the m-the fitting of the k-the operation of the n-the order.

Required

$$Q \rightarrow R^D$$

where D must satisfy the constraint requirements. Here

$$\Phi_i^k - T_i^k \geq 0$$

$$T_i^{kj} = \Phi_i^{kj} - T_i^{kj} \rightarrow \min T_i^k \sum_{j=1}^J T_i^{kj}$$

We give a description of the algorithm for solving this problem. It is solved step by step for all GPE sites. At the first step, the total labor input of the technological operations per shift (day) with a certain equipment for a specific GPE site is calculated:

$$T_i^k = \sum_{n=1}^N T_{in}^{km}$$

where is T_i^{km} the laboriousness of the operations performed with the m-the rig on the k-the GPE of the i-the site; T_{in}^{km} - the complexity of the k-the operations of the n-the order with the m-the equipment on the i-the site.

At the second step, the required number of specialized WPs is calculated for this GPE site:

$$N_i^{km} = \frac{T_i^{km}}{\Phi_i^{kj}}$$

here is N_i^{km} - the number of specialized WPs with the m-the c m-the rigging of the k-the GPE of the i-the site [5,9].

In the third step, the received number of specialized WPs, taking into account the category of qualification of workers, is introduced into the GPE section. The adjustment of the available time fund for these WPs will be carried out when planning capacity utilization as follows:

$$\Phi_i^{kj} = \Phi_i^{kj} + T_{i\text{нн}}^{kj}$$

$$T_i^{kj}$$

where is T_i^{kj} the changeover time for the j-the WP k-the GPE of the i-the site.

After that, you go to the first step. The end of the algorithm for this problem is indicated by the condition $i = S$.

SIGNIFICANCE OF THE SYSTEM

Suppose that there are three WPs (WP1, WP2, WP3) and an operation, for the histories to run, you need the rigging $D(O_1(D), O_2(D), O_3(D), O_4(D), O_5(D), O_6(D), O_7(P), O_8(P), O_9(P))$.

The complexity of the operation T_0 for all operations is 2 n / h (norm / hour). The changeover time of the tooling D to P is 15 minutes. Similarly, from П to D. The available time fund for each WP is 6 n / h.

Without taking into account the snap-in necessary for performing the operations, the WP loading schedule has the form shown in pic.1

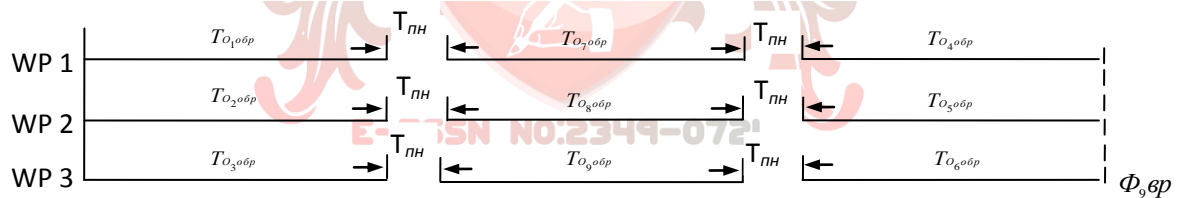

Pic.1

As can be seen from the loading schedule, the loss of time for reconfiguring the equipment for each WP is 0.5 n / h (30 min). At the first step of the algorithm, the total labor input of the technological operations for each tooling is calculated by the formula [2,8]:

$$T^D = T_{O_1} + T_{O_2} + T_{O_3} + T_{O_4} + T_{O_5} + T_{O_6} = 2 + 2 + 2 + 2 + 2 + 2 = 12 \frac{H}{u}$$

for tooling D

$$T^P = T_{O_7} + T_{O_8} + T_{O_9} = 2 + 2 + 2 = 6 \frac{H}{u}$$

for tooling P

In the second step, the required number of specialized WPs is determined by formula:

$$N^D = \frac{12}{6} = 2$$

for tooling D

$$N^P = \frac{6}{6} = 1$$

In the third step, specialized WPs are introduced into the GPE structure and, when planning to load them, the available-time fund is adjusted according to formula:

for WP1 with $-\Phi_{PM1} = 6 + 0,5 = 6,5 H/u$

for WP2c with D $-\Phi_{PM2} = 6 + 0,5 = 6,5 H/u$

for WP3c with P $-\Phi_{PM3} = 6 + 0,5 = 6,5 H/u$

Now when planning the loading of equipment, the loading schedule for WP will have the form shown in Pic. 2, where is the time reserve for WP.

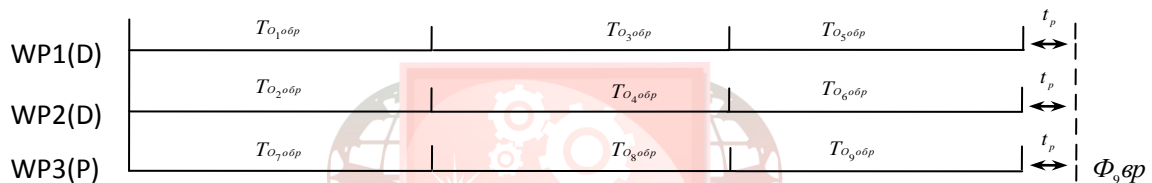

Pic.2

When you enter into the TRP specialized WP for each WP there is a time reserve for additional operations. As a result of the solution of the problem, by reducing the time spent on re-equipping the equipment, labor productivity increased at each WP.

The organization of specialized WP in the conditions of frequent change of nomenclature allows to prepare the structure of the plots flexibly for efficient loading of production capacities (the introduction of specialized WP into the structure of the GPE is reduced to the change of normative and reference information) [3,10].

The solution of this task is especially necessary for small-scale, single and pilot production. The proposed algorithm can be implemented in the tool shop of the enterprise.

MATERIAL AND METHODOLOGY

Algorithmization of synthesis of complexes of workers. Each WP can be described as follows:

$$\alpha = \{(t), H, W, x, y\}; (\alpha \in A)$$

Here Z (t) is the state of WP in the time set t;

H is the operator of transition to a new state;

W-output statement;

x-vector of the set of input signals X;

y-vector of the set of input signals Y;

A-sets of WP [4].

Let's define the model of the computing algorithm of the RM functioning; $M_i = \{\tilde{x}, \tilde{y}, \vee\}$, where V is the operator scheme of the algorithm.

The operator circuit sets the state of the algorithm at any time, has an exit operator, and determines the transition to a new state. At each moment of time, the operator circuit functions as one of the schema operators. To exit, there is a special operator. In the scheme there can be computational and logical operators [5,7].

EXPERIMENTAL RESULTS

The operator circuit is adequate to the operators H, W and the WP state z (t). The WP complex is defined as follows:

$$A = \{M, G_p\},$$

Here M is the set of models of algorithms;

G_p is a global list of model parameters.

And, $G_p = \{X^s, Y^s, B^s\}$ Here X^s, Y^s, B^s and - accordingly a set of input, output and intermediate parameters of the system.

Each element $q \in G_p$ can be represented as

$$q = \{n, e, l, o, k, c, d, m, r\},$$

Here n- is the parameter identifier;

e- the nature of the parameter;

l-is the length of the parameter;

o - the range of admissible values of the parameter;

k - the amount of data in the parameter;

c-is the type of the parameter;

d-is the way to deploy the parameter data;

m - location of the parameter;

r-is the ratio to the modules.

We define the union, intersection, and difference as the operations of such a system when solving the problem of synthesizing complexes from individual RMs [6,8]. Since the set WP is finite and there is a sufficiently complete description of the modules, we can solve in this system the problems posed as follows:

$\exists \varphi(x_1, \dots, x_k \xrightarrow{\varphi} y_1, \dots, y_i)$ where is some subset of the input parameters of the system; x_1, \dots, x_k - some subset of the output parameters of the system y_1, \dots, y_i .

In this formulation, both the input parameters of the problem and the output are known.

The algorithm for finding the solution of the problem (if the solution exists) can be described as follows: We find such a set of modules M that covers the input list. Then we check for a match the output lists of the resulting combination of modules and the output lists of the task parameters. If some of the parameters match, they are deleted from the output list of the task. The resulting union will be called a combined model of the 1st level or a complex.

PC memory is divided into two levels: upper and lower. The lower level is intended for storing a program that specifies the logic for processing input signals and generating output signals. The lower level of memory is constructively an element of the PC processor. The upper level of memory, performed on the elements of the SLM, serves to store the interchangeable bypass subroutines (cyclic graphs, fragments) of the main PC program [7].

PCs can include analog-to-digital and analog-to-digital converters. In this case, the PC acquires the property of devices. The PC on the matrix BIS can perform discrete and analog control functions, computational actions, as well as synchronization operations associated with time delays in a wide range. To ensure reliability, are usually provided with the ability to diagnose input sources (sensors) and controlled process equipment. For the same purpose, the PC is equipped with auto-diagnostic tools. Diagnostics, usually used to monitor the sources of input signals, including for switching to backup with faulty main. The control elements of the controlled output of the PC output commands enter the external machine feedback ring. The use of diagnostic tools avoids gross errors in the failure of sources of fault signals from controlled equipment. Auto diagnostics of the PC is performed with a time division. It is only diagnosed (execution of the main program of the lower level.) Top-level programs are checked only during programming and during preventive maintenance [8].

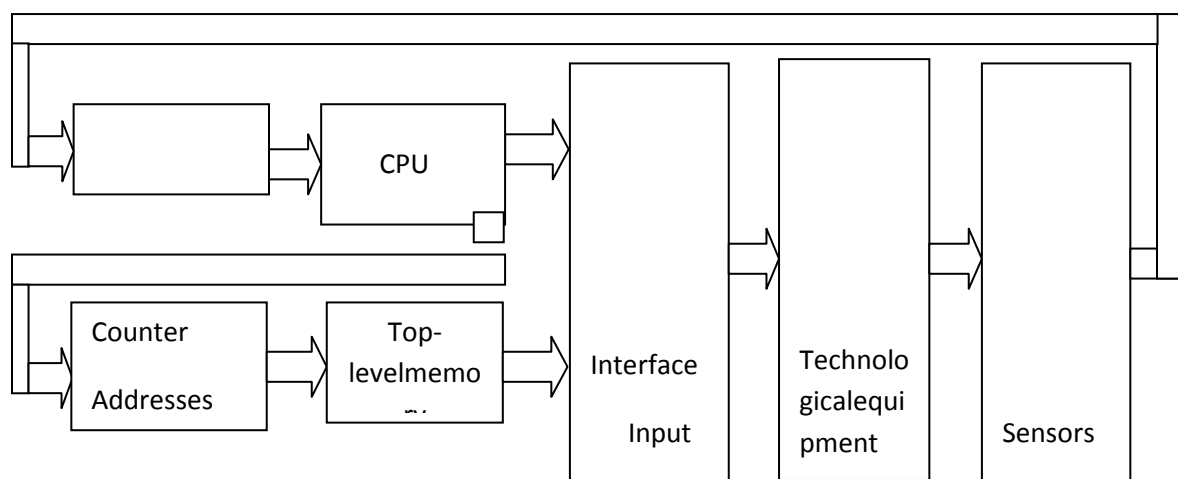

Fig. 1. Control scheme on the basis of SLM and ROM (SLM - system).

The general process of designing an LDS can be divided into the next stages: 1st stage. Development of a logical control algorithm for the projected system, i.e. A description of the sequential work of a given production module for which the LDS is projected. Based on the developed optimal technological routes and the chosen layout solution, a scheme of interaction between the elements of the module, for example, a loading device, a robot and equipment, is developed. 2nd stage. Synthesis of the logic circuit of the control automaton (VA), realizing the given algorithm, and its transformation into the electrical circuit. The third stage. Development of the design of one or more TEA, on which the scheme obtained at the 2nd stage is realized. Thus, the proposed methodology allows: to create controls for production modules on a single technological basis; increase the reliability of operation and management; Increase performance [9].

CONCLUSION

To find the level 2 complex as an input list of this level will be a list of input parameters of the complexes of the 1st level without output parameters of the system. Further, this process continues until one of the two output lists is empty: either the output list of the task parameters, which means the solution exists: either the output list of the 0-level complex, which means no solution. Solving the problem in such a formulation in practice often leads to a lack of a solution, therefore, usually the following tasks are posed:

$$\exists \varphi(x_1, \dots, x_k \xrightarrow{\varphi} y_1, \dots, y_m)$$

where the list of input parameters of the problem is known, and the output list is obtained in the process of solving the problem by the above deductive method of solution search (ie, from top to bottom). Naturally, the check of stopping of this algorithm is made on the output list of the combined module of the 3rd level.

The inverse is the statement of the problem, when only the output parameters of the problem are known. In this case, the statement is as follows:

$$\exists \varphi(y_1, \dots, y_m \xrightarrow{\varphi} x_1, \dots, x_k)$$

The algorithm for solving the problem is formulated similarly to the direct problem algorithm - by replacing the input and output parameters.

The algorithms of complex synthesis considered above allow us to obtain a model of the system [4].

With the help of CAD "Synthesis" [10] on the computer, a control program is obtained for tuning the PLM and ROM of the base TEZ on the programming equipment. In the UE there are tables of implicants for PLM1 of the building I with the number of terms 27, PLM1 of the corporation 2 - 25. As a result of solving the problem of joint minimization of systems of Boolean functions in the class of d.n.f. specified by implicit tables for 1.2 PLM1 shells, The four intermediate terms are shortened and a system of Boolean functions is realized, realized by one body of the PLM1.

REFERENCES

[1]. Kalandarov I.I., Sotiboldiyev S.U., Narzullayev Y.E. Algorithm of the choice of the optimum technological route and the group equipment // ISSN 2350-0328 International Journal of Advanced Research in Science, Engineering and Technology (India) Vol.6, Issue 5, May 2019 PP.9066-9070

- [2]. Kalandarov I.I. Algorithm of the choice of the optimum technological route and the group equipment. // ISSN: 2181-9203 Science and education in Karakalpakstan, Nukus, Vol. 3 (11), 2019 PP.27-32
- [3]. Kabulov A.V., Normatov I.H., Kalandarov I.I. Algorithmic model of management on the basis of algebra over functioning tables (FT) // ISSN 2308-4804 International scientific journal "Science and World", № 1(17), 2015. - Vol. 1 - PP. 10-13
- [4]. Kabulov A.V., Normatov I. Kh., Kalandarov I. I. Algorithmic models of management of complex systems based on tables of functioning // Collection of articles of the winners of the International scientific and practical conference held on December 15, 2016 in Penza, PP. 66-68
- [5]. Kabulov A.V., Normatov I.X., Kalandarov I.I., Karimov A.A. Algorithmic method of organization of specialized workshops // ISSN:2350-0328 International Journal of Advanced Research in Science, Engineering and Technology (India) Vol. 5, Issue 4 , April 2018 PP.5670-5675
- [6]. Kalandarov I.I., Bekbalaev S. Algorithm for solving the optimal technological route tasks // ISBN 978-5-6043626-2-4, Society of science and creativity, sat.St "Initiative in science as a new way of developing the knowledge system системызнаний", Kazan, 2019, PP. 270-275
- [7]. Kabulov A.V., Normatov I. Kh., Kalandarov I. I. Algorithmic approach to managing complex systems on the example of production systems // DAN an RUz, Tashkent, no. 1, 2017 PP. 33-35
- [8]. Kabulov A.V., Normatov I. Kh., Kalandarov I. I. Algorithmic model of control based on algebra over tables of functioning // ISSN 2181-8460 "Problems of computational and applied mathematics". Center for development of software products and hardware and software complexes (Tashkent) № 2 (4). 2016. PP.19-23
- [9]. Kabulov A.V., Normatov I.H., Kalandarov I.I. Algorithmic method of the conversion functioning tables (FT) for control industrial systems. // ISSN 2308-4804 International scientific journal "Science and World", № 8(24), 2015. - Vol. 1 - PP.14-17
- [10]. Kabulov A.V., Kalandarov I. I. Description of The architecture of the Atlas algorithmic system // In the collection: Innovative geotechnologies in the development of ore and non-metal deposits Collection of reports of the VII International scientific and technical conference within the framework of the Ural mining decade. Yekaterinburg. 2018. PP. 470-475.